

AGILITY IN MOTION

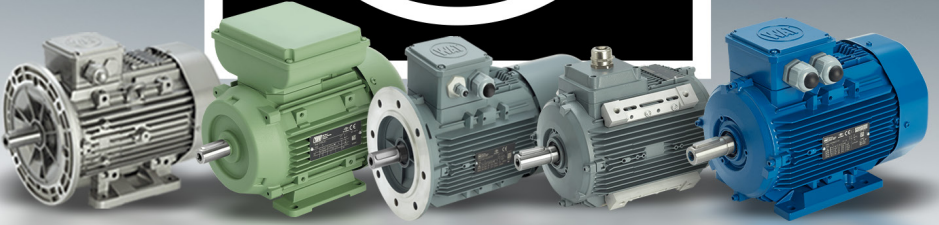

**ELECTRIC MOTORS**  
OPERATING MANUAL



wat.com.tr

# Please read this manual first!

Dear Customer,

We wish that your product, manufactured in modern facilities and subjected to meticulous quality control processes, will provide you with the best performance. Therefore, we kindly request that you carefully read this guide in full before using your product and keep it as a reference.

This operating manual:

- Will help you use your motor quickly and safely.
- Read the operating instructions before operating and starting your motor.
- Follow the instructions, particularly those related to safety.
- Keep the operating manual in an easily accessible place in case you need it later.
- Also, read the other documents provided with the motor. Please keep in mind that this operating manual may also apply to other models. The differences between the models are clearly highlighted in the manual.

## Symbols and their explanations

The following symbols are used in the operating manual:



**Warning against conditions that are hazardous to life and property**



**Warning against electrical voltage**



**Marking important information related to the subject**



This product is manufactured in environmentally-friendly modern facilities without causing any harm to nature.



# Table of Contents

<b>Three-Phase Aluminum-Housed Motors</b>	<b>05</b>
<b>01</b> Safety Warnings	06
<b>02</b> Models	07
<b>03</b> Norms and Conditions of Use	10
<b>04</b> Storage and Handling	12
<b>05</b> Installation and Mechanical Connections	14
<b>06</b> Operation	16
<b>07</b> Electrical Connections and Grounding	20
<b>08</b> Operating Motors with Inverters	24
<b>09</b> Rating Plate	25
<b>10</b> Maintenance	26
<b>11</b> Spare Parts	30
<b>12</b> Customer Service and Support	32
<b>Braked Motors Maintenance, Installation, and Operation Instructions</b>	<b>35</b>
<b>Smoke Extraction Motors Operating Manual</b>	<b>41</b>
<b>Operating Manual For Marine Motors</b>	<b>67</b>

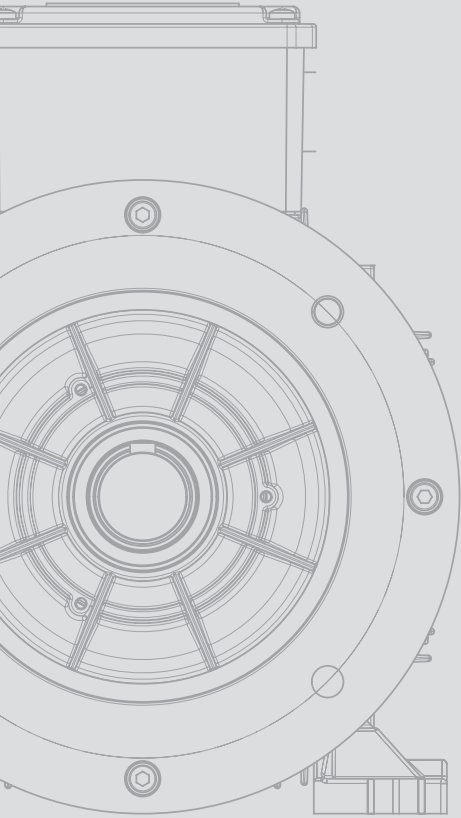

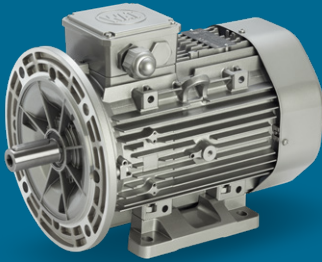

# THREE-PHASE ALUMINUM -HOUSED MOTORS



# 01

## Safety Warnings

**Certain precautions shall be taken before installation to ensure a trouble-free operation. The training and knowledge level of the person who will perform the mechanical and electrical connections shall be taken into consideration. Serious injuries and damage to property may occur if unqualified persons are involved.**

- Operation, maintenance, and troubleshooting of electric motors shall only be performed by qualified personnel.
- Observe the technical information provided in the catalogues and on the rating plate of the electric motor. Carefully review the operating instructions.
- Disconnection and reconnection of electrical power shall be performed by authorized personnel.
- Before performing maintenance on an electric motor, disconnect the power supply of the motor to prevent electric shock and secure the area with warning signs.
- As the electric motor has rotating parts, do not intervene until the motor has completely stopped, even if the power supply is interrupted.
- Inspect electrical and mechanical connections before supplying power to the electric motor. Verify that grounding is appropriate.
- Ensure that the clamp connections are tightened to the correct torque and that the connection does not lead to any adverse conditions.

The warnings provided in the operating and maintenance instructions, the instructions for the commissioning, installation, and inspection of the motor, and all maintenance instructions apply to qualified personnel **(who are familiar with the safety standards specified in IEC 60364 and TS HD 60364)**. Factors affecting human health, such as injuries and damage to equipment, improper installation, irregular maintenance, failure to take necessary precautions, inappropriate electrical and mechanical connections, and failure to take safety precautions during installation, may be observed. The necessary preventive actions shall be taken against these risks.

# 02

## Models

The Three-phase and Single-phase motor models covered in the installation and operating manual are defined with the following code structure.

Q1E, Q2E, Q3E, Q4E, Q1H, Q2H, Q3H, Q4H, Q2N, Q3N, Q4N  
 Q1HS, Q2HS, Q3HS, Q4HS, Q1HG, Q2HG, Q3HG, Q4HG, Q1HSG, Q2HSG,  
 Q3HSG, Q4HSG  
 Q1EP, Q2EP, Q3EP, Q4EP, K1H, K2H, K3H, K4H, K1HG, K2HG, K3HG, K4HG  
 Q1B, Q2B, Q3B,  
 QB, QM, QC, Q2

MODEL	Q	3	E	-	FA	225	M	4	C	40	BN	UL
	a	b	c	d	e	f	g	h	i	j	k	
	Q	-	E	-	-	63	S	2	-	-	-	
	K	1	Y	G,P	FA	71	M	4	A	0-99	AA-ZZ	
	S	2	MY		FB	80	L	6	B			
	M	3	CY		FC	90	LH	8	C			
		4	H		FS	100		2-4	D			
			HS		PA	112		4-8	DE			
			N		PB	132		2-12	E			
			NR		PC	160		4-16	K			
			C		PS	200						
			CN		X	225						
			B			250						
			M			280						
			MN			315						
			MH			355						
						400						
						450						

<b>a:</b>	Motor Series
<b>b:</b>	Efficiency Class
<b>c:</b>	Motor Type
<b>d:</b>	Body Type
<b>e:</b>	Construction Type
<b>f:</b>	Body Size
<b>g:</b>	Body Size
<b>h:</b>	Number of Poles
<b>i:</b>	Sheet Length
<b>j:</b>	Specific Motor Number
<b>k:</b>	UL Approval

# Q3EPFA225M4C43

(Sample model number)

## Q3E / Motor Type

Motors with Q4H IE4 efficiency class

Motors with Q3H IE3 efficiency class

Motors with Q2H IE2 efficiency class

Motors with Q3HS IE3 efficiency class

Motors with Q2HS IE2 efficiency class

Motors with Q4E IE4 efficiency class

Motors with Q3E IE3 efficiency class

Motors with Q2E IE2 efficiency class

Motors with Q3N IE3 efficiency class

Motors with Q2N IE2 efficiency class

Fume extraction motors with S3H IE3 efficiency class - F300

Fume extraction motors with S2H IE2 efficiency class - F300

Fume extraction motors with S3HG IE3 efficiency class - F400

Fume extraction motors with S2HG IE2 efficiency class - F400

Permanent split capacitor single-phase motors with Q2MN IE2 efficiency class

Start and permanent split capacitor single-phase motors with Q2CN IE2 efficiency class

Motors with K4H IE4 efficiency class - Special Purpose Compressor Series

Motors with K3H IE3 efficiency class - Special Purpose Compressor Series

Motors with K2H IE2 efficiency class - Special Purpose Compressor Series

Motors with M4H IE4 efficiency class - Marine Motor Series

Motors with M3H IE3 efficiency class - Marine Motor Series

Motors with M2H IE2 efficiency class - Marine Motor Series

## P3 / Body Type

----- Aluminum

P or G Cast Iron

### FA / Construction Type

-----	Foot Mounted	B3, B6, B7, B8, V5, V6
FA	B5 Flange Mounted	B5, V1, V3
FB	B14b Flange Mounted	B14, V18, V19
FC	B14 Flange Mounted	B14, V18, V19
FS	Special Flange Mounted	-----
PA	B5 Flange Mounted and Foot Mounted	B35, V15, V36
PB	B14b Flange Mounted and Foot Mounted	B34, V58, V69
PC	B14 Flange Mounted and Foot Mounted	B34, V58, V69
PS	Special Flange Mounted and Foot Mounted	-----
X	Without Foot, Flange and/or Cover	B9, V8, V9

### 225 / Frame Size Shaft Height (mm)

### M / Body Size

S	Short
M	Medium
L	Long
H	Longer

### 4 / Number of Poles

2  
4  
6  
8  
2-4  
4-8  
2-12  
4-16

### C / Sheet Length

A  
B  
C  
D  
DE  
E  
K

### 43 / Specific Motor Number

# 03

## Norms, Standards, and Conditions of Use

**WAT electric motors are manufactured in compliance with international standards.**

<b>IEC 60034-1</b>	Classification and performance
<b>IEC 60034-2-1</b>	Loss and efficiency measurement methods
<b>IEC 60034-5</b>	Classification of protection rating
<b>IEC 60034-6</b>	Cooling methods
<b>IEC 60034-7</b>	Symbols for construction and mounting arrangements
<b>IEC 60034-8</b>	Terminal markings and direction of rotation
<b>IEC 60034-9</b>	Noise limits
<b>IEC 60034-11</b>	Thermal protection
<b>IEC 60034-12</b>	Starting Properties
<b>IEC 60034-14</b>	Vibration limits
<b>IEC 60034-18-1</b>	Functional evaluation of insulation systems
<b>IEC 60034-18-41</b>	Partial discharge-free electrical insulation systems used in rotating electrical machines powered by voltage transformers
<b>IEC 60085</b>	Thermal testing of insulation materials used in electrical machinery
<b>IEC 60034-30-1 ve 30-2</b>	Classification of efficiency
<b>IEC 60038</b>	Standard voltages
<b>TS EN 50347 &amp; IEC 60072-1 ve 2</b>	Dimensions and output power for electric machines
<b>EN 55014-1</b>	
<b>EN 61000-3-2</b>	Electromagnetic compatibility
<b>EN 61000-3-3</b>	

During the maintenance and inspection of the motor, necessary precautions shall be taken for circuits and connections that may be under voltage. Motors shall be protected against excessive loads by fuses, thermal protection, thermistors, thermal switches, or electronic protection circuits suitable for the full load current specified on the rating plate. The appropriate selection and accuracy of these circuits shall be verified.

The specifications provided on the rating plate of the motor, the relevant standards, and the conditions specified in this manual must be observed for the warranty to be valid.

# Environmental specifications

According to IEC 60034-1, three-phase and single-phase motors are designed to operate at a maximum altitude of 1000 meters above sea level and within an ambient temperature range of -20 to +40°C. The following coefficients, expressed as percentages, shall be used for the power calculations at other altitudes and ambient temperatures.

Height		Up to 1000 m	Up to 1500 m	Up to 2000 m	Up to 2500 m	Up to 3000 m	Up to 3500 m	Up to 4000 m
In % by insulation class Times of the catalogue powers	B	100	97	94	90	86	82	77
	F	100	98	95	91	87	83	78

Ambient temperature		30°C	35°C	40°C	45°C	50°C	55°C	60°C
In % by insulation class Times of the catalogue powers	B	106	106	100	97	92	86	60
	F	105	102	100	97	93	87	82

# 04

## Storage & Handling

Motors are shipped from our factory fully assembled and ready for use. Before installing the motors, inspect whether they have suffered any damage during transport.

Motors shall be stored in their original packaging. If there is any damage to the packaging, it shall be repaired. For long-term storage, they shall be kept away from environmental vibrations, protected from water ingress, and maintained at a constant temperature. To prevent bearing damage, environment conditions with a maximum vibration value of  $V_{eff} < 0.20 \text{ mm/s}$ , dry, and free of dust shall be provided.

The lifting eyes on the motor are designed only for handling the motor. They shall not be used for the purpose of carrying extra loads. Check the tightness of the lifting eyes before use.

Measure the insulation resistance of motors before shipping them under long-term storage conditions. If the motor windings are damaged due to moisture during storage, measure the insulation resistance and make a decision about the motor based on the table below.

- In case it is  $2 \text{ M}\Omega$  or less, always have it inspected by an authorized service.
- In case it is between  $2 \text{ M}\Omega$  and  $50 \text{ M}\Omega$ , it shall be considered at a dangerous level;
- In case it is between  $50 \text{ M}\Omega$  and  $100 \text{ M}\Omega$ , it shall be considered at a normal level;
- In case it is greater than  $50 \text{ M}\Omega$ , it shall be considered as suitable.



There is a risk of electric shock when operating an electric motor with an improper measured insulation resistance. Do not operate the motor under any circumstances.



The measurement of insulation resistance is performed on a de-energized and stationary motor.

The body of the motor and any thermal protectors shall be grounded.

- In the event of any damage, you shall notify the authorized person and keep a record of the damage.
- It shall be transported on wooden pallets in accordance with the instructions during storage or shipment.
- It shall be stacked in accordance with the instructions.
- Do not open the packaging of electric motors during storage.



If long-term storage is required;

- The storage area shall be enclosed and covered.
- Vibrations shall be prevented.
- The ambient temperature shall be kept between  $-15^{\circ}\text{C}$  and  $40^{\circ}\text{C}$ .
- Relative humidity shall be  $<50\%$ .
- It shall be kept away from chemical gases.
- The storage area shall be protected against rodents..

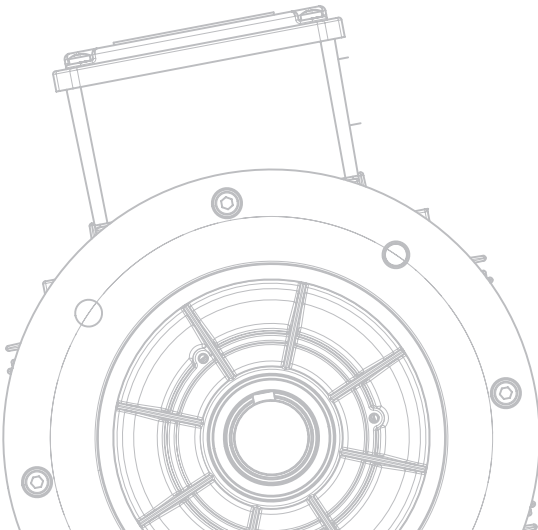

# 05

## Installation and Mechanical Connections

### Before starting the assembly

- Check whether the motor has been damaged during transport or storage.
- Check whether the information provided on the motor is suitable for the available mains voltage.
- Check the information on the motor for the suitability of the location where it will be used.
- Check that any accessories on the motor are complete and in operational condition.

### Preparation

- Remove the corrosion-resistant plastic protective cover and any materials from the motor shaft.
- Check for friction by rotating the motor shaft by hand.
- Measure the insulation resistance. Do not use the motor if the insulation resistance is not appropriate.
- The motors are dynamically balanced with a half-key placed at the shaft end. Therefore, the transmission elements shall be balanced with a half-key.

### Installation

- The motor shall be mounted on a flat, vibration-damping surface that is resistant to torsion. The motor can be mounted on the feet or the cover.
- The load and motor shaft shall be on the same axis and parallel to each other.
- Ensure that the cooling air intake of the motor is unobstructed.
- Ensure that the terminal box and cover remain accessible after installation for electrical connections.

## Balancing, alignment

In order to prevent damage to the bearings during the installation of pulleys, couplings, and other transmission components, pay attention to avoid subjecting the motor to impact and stress. If the necessary tools and equipment are available to install the transmission components with the required precision, it is recommended to heat them to 60-80°C before installation. The transmission elements shall be properly seated and tightened against the shaft shoulder to ensure no clearance remains after assembly.

If the motors are connected with couplings, the alignments shall be properly performed and measured. The motor may vibrate if the alignment is not correct. If the offset is too large, some parts may break or become damaged.

For the alignment and levelling of couplings, it is important to consider the effect of the temperature of the motor and the pump being driven. Different expansion levels in coupling systems may affect the alignment/levelling during operation. Therefore, it is important to leave an axial clearance (min. 3mm) between the couplings. Bearings may be damaged due to excessive vibration when they are out of alignment due to temperature.



In belt and pulley applications, pulleys shall be positioned parallel to each other and aligned with the belt using the appropriate belt and tension.



Excessive tension that may occur in the belt can cause excessive vibration in the system and even lead to breakage of the shaft. For a motor balanced according to the half-key balance, pulleys and couplings balanced according to the half-key balance shall be used.



The user is responsible for the proper installation of the electric motor.



The installation ground of the motor shall be of a structure capable of withstanding the motor's weight and mechanical forces. The size and dimensions of the bolts to be used to secure the motor shall not cause vibration in the motor.

# 06

## Operation

Motors shall be protected against excessive loads by fuses, thermal protection, thermistors, thermal switches, or electronic protection circuits suitable for the full load current specified on the rating plate. The appropriate selection and accuracy of these circuits shall be verified. Squirrel-cage asynchronous motors draw 6-7 times the rated current specified on the rating plate from the mains when they are started directly. Thus, the electrical connections of the electric motor shall be selected to withstand this high current. It shall be inspected whether the sudden high torque generated in the motor could damage the system.

An insufficient power source or a power cable that is too long or too short, or with a low cross-section, will cause a voltage drop in the motor.



The nearest object to the air intake side of the motor shall be positioned at a distance of at least one-fourth of the hole diameter of the fan guard housing.

Y/ $\Delta$  starting shall be used in three-phase asynchronous motors to enable soft starting of the motor.

(It is recommended to use Y/ $\Delta$  starting for motors rated at 4kW and above.)

Points to consider during the first operation are as follows.

- Measurements shall be taken and observations made to ensure that the electric motor is delivered in good condition from storage.
- The mechanical and electrical connections of the electric motor shall be inspected to ensure they are made completely and correctly.
- This shall be checked against the connection diagram.
- Inspect the direction of rotation of the motor.
- Inspect the ventilation of the motor. Confirm that the air intake is open.
- Check that the terminal box is closed.
- Check that all system and motor bolts are installed and tightened.

- Check the physical suitability of the system by turning the motor shaft by hand, if possible.
- You can start the motor after this step. Check for any vibration in the motor during operation. Monitor for an increase in temperature in the bearings.
- When the electric motor is loaded, the current and power information specified on the rating plate is compared with the measurement results.
- The increase in motor temperature stabilizes within 2-3 hours when it is operated at its rated load. Measure the relevance of this value.

Points to consider when determining the appropriate motor for the load are as follows;

- Mains Voltage
- Frequency
- Load characteristics and value
- Ambient conditions
- Construction type
- Service factor
- Operating mode

 For WAT and TEE brand three-phase asynchronous electric motors with a starting current higher than 31 amperes, the conditions specified in standards EN61000-3-3 and EN61000-3-11 shall be considered, or the motors shall be connected to a network with a current capacity greater than 100A.

 **Important note for QM and QC models** of WAT and TEE brand single-phase asynchronous electric motors: For single-phase motors with a starting current higher than 26 A, the conditions specified in standards EN 61000-3-3 and EN 61000-3-1 No. 1 shall be considered, or the motors shall be connected to a network with a current capacity greater than 100 A.

## Vibration & Balance

All rotors are dynamically balanced with half key and this is indicated by the letter “H” on the rating plate of the motor. Vibration level A is ensured in standard motors according to IEC 60034-14. On request, it is possible to manufacture motors with vibration level B.

Vibration Class	Shaft Height [mm]	56≤H≤132		H>132	
	Connection Type	Replacement μm	Hu [mm/s]	Replacement μm	Speed [mm/s]
A	Independent Suspension	45	2.3	45	2.3
	Rigid Connection	-	-	37	2.3 2.8*
B	Independent Suspension	18	1.1	29	13
	Rigid Connection	-	-	24	1.5 1.8*

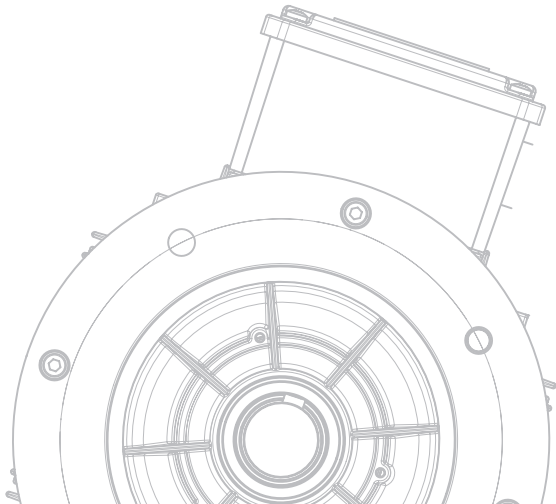

## Tolerances

Tolerances for deviations from catalog values according to IEC 60034-1 shall be assessed according to the following table.

Speed (n)	$\Delta n = \pm 20\%(n_s - n_N)$ , $P_N > 1\text{kW}$
	$\Delta n = \pm 30\%(n_s - n_N)$ , $P_N \leq 1\text{kW}$
Efficiency % [η]	$\Delta \eta = -15\%(100 - \eta_N)$ , $P_N \leq 150\text{kW}$
	$\Delta \eta = -10\%(100 - \eta_N)$ , $P_N > 150\text{kW}$
Power Factor [cos Q]	$\Delta \cos Q = -1/6(1 - \cos Q)$
Locked Rotor Current [ $I_L/I_N$ ]	$\Delta(I_L/I_N) = +20\%(I_L/I_N)$
Locked Rotor Moment [ML/MN]	$\min(M_L/M_N) = -15\%(M_L/M_N)$
	$\max(M_L/M_N) = +25\%(M_L/M_N)$
Rolling Moment [MK/MN]	$\Delta(M_K/M_N) = -10\%(M_K/M_N)$
Saddle Moment [Mp/MN]	$\Delta(M_P/M_N) = -15\%(M_P/M_N)$
Moment of Inertia (J) [kgm <sup>2</sup> ]	$\Delta J = \pm 10\%J$
Noise Level (LPA) [dB]	$\Delta \text{LPA} = +3\text{dB(A)}$



The measured motor current shall never exceed the nominal current value stated on the rating plate.

# 07

## Electrical Connections and Grounding

The electrical connections for WAT and TEE branded three-phase and single-phase asynchronous motors shall be as indicated in the following illustrations.

### For three-phase asynchronous motors;

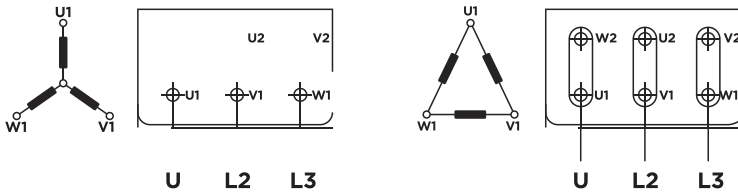

### For double-speed electric motors;

Connection Diagram for Motors with Two Separate Windings: \_\_\_\_\_

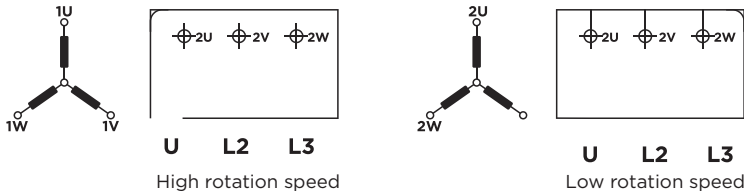

Connection Diagram for Dahlander Motor: \_\_\_\_\_

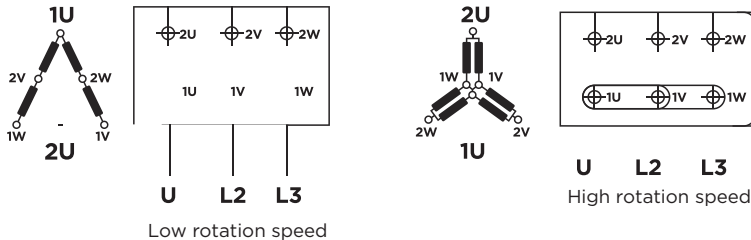

## For Dual Voltage Motors;

(9-lead motors with YY / Y connection configurations): \_\_\_\_\_

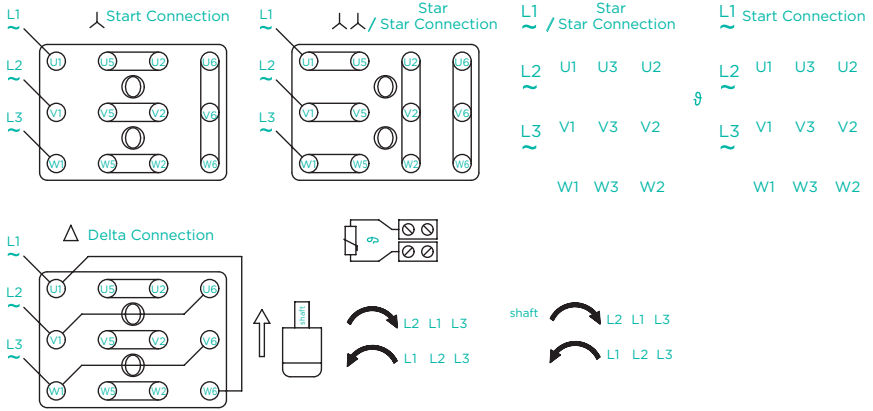

## For single-phase asynchronous motors;

Electrical connections for QM models shall be made as follows.

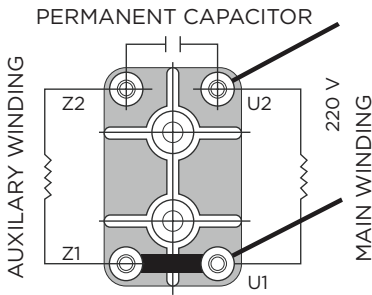

Electrical connections for QC models shall be made as follows.

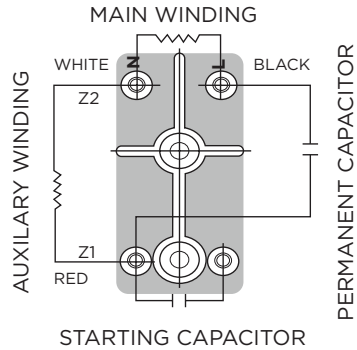

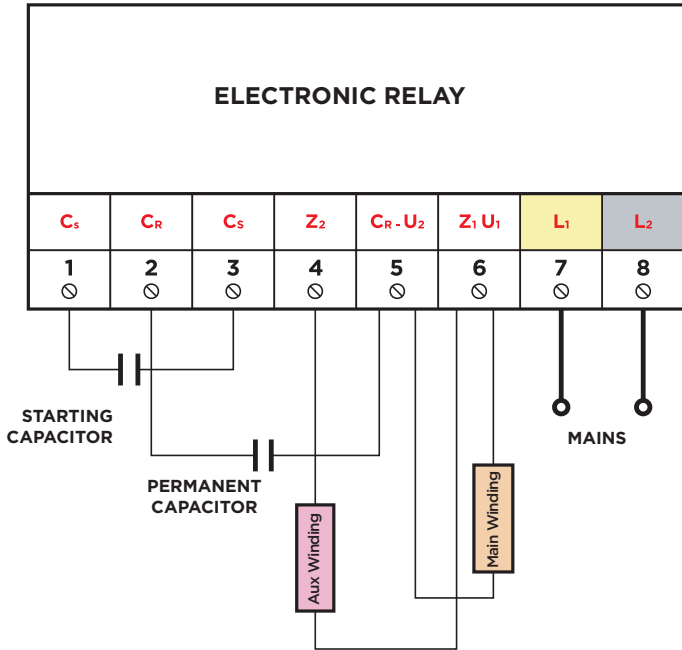

When voltage is applied to the motor, the electronic relay activates the starting capacitor. The electronic relay monitors the auxiliary winding voltage of the motor from the moment it starts up. The electronic relay disconnects the starting capacitor if the motor's auxiliary winding voltage reaches a certain value within 5 seconds. If the auxiliary winding voltage does not reach a certain value within 5 seconds, the time limiter activates and disconnects the starting capacitor. The electronic relay will remain active as a current carrier when the start capacitor is disconnected. Do not switch the terminals on the electronic relay without disconnecting the mains voltage.

The motors are connected so that the direction of rotation is counterclockwise when observed from the shaft end. You can simply swap the Z1 and Z2 terminals to change the direction of rotation. Disconnect the power supply to the motor while switching the terminals. Always use a suitable cable clamp for the terminal connection.

## Tightening Torque Values for Terminal Clamps: (N.m )

 CONNECTION BRIDGE	Tightening Torque Values for Terminal Busbar Clamping Nuts						
	Structural Size	M4 (± 0,5 )	M5 (± 0,5 )	M6 (± 0,5 )	M8 (± 0,5 )	M10 (± 0,5 )	M16 (± 0,5 )
63-71-80	1,5						
90-100-112		2					
132-160			3,5				
180-200				6			
225-250-280					8		
315						14	

### Direction of rotation

#### For Three-Phase Motors;

You can switch the motor's rotation direction by swapping the positions of the two phases. Once the installation is complete, tighten the box cover carefully to ensure the terminal box meets IP specifications.

#### For QM, QC, Q2MN, and Q2CN model Single-Phase Motors;

You can switch the direction of the motor by swapping the auxiliary winding brushes (Z1-Z2). Once the installation is complete, tighten the box cover carefully to ensure the terminal box meets IP specifications.

The user is responsible for the proper connection of electrical connections using the fittings and diagrams provided in the electric motor terminal box (nuts, washers, spring washers).

Close the box cover and tighten it securely to hold the IP cards in place after making the necessary connections in the terminal box. Box covers left open can cause electric shocks and damage to property.

### Grounding

The electrical connection system between metal and conductive parts capable of carrying current and the ground is called grounding in places where electrical energy is used.

The purpose of grounding in electrical installations is to ensure the safety of persons using electrical equipment and to prevent damage to the equipment. The grounding circuit shall be made of a low-resistance conductor (copper or aluminum), shall be capable of carrying the maximum leakage current that may occur in the circuit of the connected device, and shall be installed in a way that protects it from mechanical and chemical influences. The motor body and terminal box shall be grounded. The electrical connections shall be completed using the grounding terminal inside the terminal box and the grounding screw on the motor foot. The grounding resistance shall be less than 1 ohm.

# 08

## Operating Motors with Inverters

Squirrel-cage asynchronous motors are the most popular type of motor in industry due to their ease of manufacture, simple and robust construction, low cost, and low maintenance requirements. Efforts to improve energy efficiency, technological advances in power electronics and circuits, and the accompanying reduction in costs particularly in recent years have led to an increasing use of inverters in asynchronous motors.

This technical information considers two different operating modes for inverter parameter settings

- Open-loop operating mode (V/f control)
- Vector control

The parameter settings provided in the technical information note apply to the specified model of the relevant company. You need to review the user manuals for different models from different manufacturers.

### Open-loop or V/f operation

This operating mode is based on keeping the V/f ratio constant and maintaining a constant motor electric field flux  $\Phi$ . No speed feedback from the motor is required in this operating mode. Therefore, devices such as encoders and tachometers are not required. This operating mode requires the rating plate information of the motor to be correctly introduced to the inverter.

### Vector control

This algorithm determines the optimal operating point based on the motor load, ensuring the motor operates at its most efficient point. However, not every inverter model features a vector control mode. Information regarding whether this mode is available in the purchased inverter shall be obtained from the inverter catalogue or the supplier. The most critical factor in the vector control algorithm is the accurate detection of motor parameters and setting these parameters in the inverter. Thus, we recommend that the motor parameters shall be obtained from the motor manufacturer. If possible, the motor parameters received from the motor manufacturer shall be checked for conformance with the values calculated by the inverter in its autotune mode.

# 09

## Rating Plate

The rating plate of the electric motor is as follows. The plate may feature the WAT or TEE branded logo.

According to the EC 640/2009 Directive, motor rating plates shall display 50Hz and 60Hz motor data, IE codes, and efficiency values.

Thanks to the 2D barcodes available on our WAT and TEE-branded motors, it is possible to access traceability information such as the motor's production date, routine test results (neutral, current, resistance, power, etc.), and serial number.

The rating plate contains the following information:

- Logos:** WAT Motor Sanayi ve Ticaret A.Ş. Made in Türkiye, TSE (TS EN 60034-1), CE, IE4, and a QR code.
- Motor Type:** 3~Mot
- Motor Code:** Q4H 90L4D
- Year of Production:** 2024
- Insulation Class:** H
- IP Protection Class:** IP 55
- Operating Mode:** Icl F S1
- Efficiency Class:** IE4
- Motor Weight:** Kg 20
- Service Factor:** S.F. : 1.15
- Manufacturing Tracking Number (Serial Number):** 01012024
- IEC Code:** IEC 60034

$\frac{V}{\Delta/\lambda}$	Hz	r/min	kW	Cos $\Phi$	A	$\eta$ 100%	$\eta$ 75%	$\eta$ 50%
230/400	50	1461	1.1	0.64	4.95 / 2.86	IE4-87.2%	85.5%	81.5%
265/460	60	1766	1.1	0.62	4.49 / 2.59	IE4-87.5%	85.7%	81.7%

- Motor Type
- Motor Code
- Year of Production
- Insulation Class
- IP Protection Class
- Operating Mode
- Efficiency Class (According to 60034-30-1)
- QR code
- Service Factor
- Motor Weight
- Efficiency Value (According to 60034-2-1)
- Efficiency Value
- Efficiency Value
- Nominal Current Value
- Power Factor
- Motor Output Power
- RPM
- Motor Nominal Frequency
- Operating Voltage
- Manufacturing Tracking Number (Serial Number)

# 10

## Maintenance

The following parameters shall be observed when operating electric motors.

- The temperature levels of the bearings and the winding shall be monitored.
- The ventilation ducts of the motor shall be cleaned to ensure proper cooling of the motor.
- The vibration level of the system shall be monitored.
- Insulation resistance shall be measured at regular intervals.
- The accessories available on the motor shall be inspected.
- The condition of load transfer elements shall be monitored.

The following issues can be addressed by qualified personnel before contacting the service department in case of a potential malfunction.

Abnormal Condition	Possible Causes	Remedy
Noisy operation	<ol style="list-style-type: none"><li>1. Loose parts. (Foot, pulley, etc.)</li><li>2. Broken or bent fan blades</li><li>3. Damaged motor bearings</li><li>4. There is an error in the mechanical connection of the motor.</li><li>5. Broken bearing tension spring.</li><li>6. Fan friction</li><li>7. The motor runs in two phases.</li><li>8. Loose connections</li><li>9. Broken rotor bar</li></ol>	<ol style="list-style-type: none"><li>1. Tighten the connections.</li><li>2. Replace the fan.</li><li>3. Check motor bearings.</li><li>4. Check and fix the mechanical connection.</li><li>5. Replace the bearing tension spring.</li><li>6. Prevent friction.</li><li>7. Identify the cause and correct it.</li><li>8. Tighten the connections.</li><li>9. Contact the service department.</li></ol>
Overheating	<ol style="list-style-type: none"><li>1. Low mains voltage.</li><li>2. Motor overloaded.</li><li>3. The motor runs in two phases.</li><li>4. Fan is broken.</li><li>5. Faulty rotor</li><li>6. Ambient temperature is too high.</li><li>7. The air intake to the motor is blocked.</li><li>8. A coil has short-circuited.</li><li>9. The bearings are damaged.</li></ol>	<ol style="list-style-type: none"><li>1. Identify the cause and correct it.</li><li>2. Check if the motor is suitable for the load.</li><li>3. Identify the cause and correct it.</li><li>4. Replace the fan.</li><li>5. Replace the rotor.</li><li>6. Use a specific motor.</li><li>7. Identify the cause and correct it.</li><li>8. Contact the service department.</li><li>9. Check motor bearings.</li></ol>

Abnormal Condition	Possible Causes	Remedy
The motor is not operating; there is no magnetic whining sound.	<ol style="list-style-type: none"> <li>1. The fuse is blown or missing.</li> <li>2. Thermal fuse is blown.</li> <li>3. Improper or loose cable connections.</li> <li>4. The switch is open.</li> </ol>	<ol style="list-style-type: none"> <li>1. Check the fuse.</li> <li>2. Check the thermal fuse.</li> <li>3. Check the cable connections.</li> <li>4. Check the switch.</li> </ol>
The motor is not operating; there is magnetic whining sound, thermal fuse blows.	<ol style="list-style-type: none"> <li>1. Improper cable connections.</li> <li>2. Low mains voltage.</li> <li>3. Short circuit or break in the motor windings.</li> <li>4. Mechanical seizure within the motor.</li> <li>5. Auxiliary winding is disabled.</li> <li>6. Faulty capacitor.</li> <li>7. The motor runs in two phases</li> <li>8. Relay faulty.</li> </ol>	<ol style="list-style-type: none"> <li>1. Check the cable connections.</li> <li>2. Identify the cause and correct it.</li> <li>3. Contact the service department.</li> <li>4. Check motor bearings.</li> <li>5. Identify the cause and correct it.</li> <li>6. Replace the capacitor.</li> <li>7. Replace the relay.</li> </ol>
The motor starts and operates, but the thermal fuse trips shortly thereafter.	<ol style="list-style-type: none"> <li>1. Low mains voltage.</li> <li>2. Thermal fuse faulty.</li> <li>3. Motor overloaded.</li> <li>4. The motor runs in two phases.</li> </ol>	<ol style="list-style-type: none"> <li>1. Identify the cause and correct it.</li> <li>2. Check the thermal fuse.</li> <li>3. Check if the motor is suitable for the load.</li> <li>4. Identify the cause and correct it.</li> </ol>
It is not possible to start the motor.	<p><i>When the motor is idling;</i></p> <ol style="list-style-type: none"> <li>1. Broken rotor bars.</li> <li>2. Low mains voltage.</li> <li>3. The motor runs in two phases.</li> <li>4. Loose connections.</li> <li>5. Incorrect connection.</li> <li>6. Mechanical seizure within the motor.</li> </ol> <p><i>When the motor is loaded, additionally,</i></p> <ol style="list-style-type: none"> <li>7. Motor is overloaded.</li> <li>8. Relay is faulty.</li> <li>9. The duration of the time relay is not sufficient.</li> <li>10. Broken wire in the main or auxiliary winding.</li> </ol>	<ol style="list-style-type: none"> <li>1. Contact the service department.</li> <li>2. Identify the cause and correct it.</li> <li>3. Identify the cause and correct it.</li> <li>4. Tighten the connections.</li> <li>5. Check the connections.</li> <li>6. Check motor bearings.</li> <li>7. Check if the motor is suitable for the load.</li> <li>8. Replace the relay.</li> <li>9. Change the duration of the time relay.</li> <li>10. Replace the coils or the faulty coil.</li> </ol>
Capacitor blows.	<ol style="list-style-type: none"> <li>1. Very frequent starting at load.</li> <li>2. Excessive vibration in the motor.</li> <li>3. Incorrect connection.</li> <li>4. Capacitor selected with incorrect micro-farad or voltage value.</li> </ol>	<ol style="list-style-type: none"> <li>1. Use a specific motor.</li> <li>2. Fix the vibration.</li> <li>3. Fix the connection.</li> <li>4. Select a proper capacitor..</li> </ol>

## Bearings

Maintenance is not required for motors using sealed (ZZ) bearings, as the bearings are lubricated with the type of oil specified by the manufacturer. Bearings shall be replaced after 20,000 hours of operation (approximately 2-5 years of operation) in the specified operating temperature, vibration level, and shaft loads.

Under abnormal operating conditions, bearings shall be replaced at an earlier interval if excessive noise, vibration, or heat is detected. In such cases, the connecting elements (couplings, belts, pulleys, etc.) that connect the motor shaft to the load shall be inspected.

			DE	NDE
<b>ALUMINUM BODY</b>	63	E	6201 ZZ	6201 ZZ
	71	E	6202 ZZ	6202 ZZ
	80	H	6204 ZZ	6204 ZZ
		N	6204 ZZ	6204 ZZ
	90	H	6305 ZZ	6205 ZZ
		HS	6305 ZZ	6204 ZZ
		N	6205 ZZ	6205 ZZ
	100	H	6306 ZZ	6205 ZZ
		HS	6306 ZZ	6205 ZZ
		N	6206 ZZ	6206 ZZ
	112	H	6306 ZZ	6206 ZZ
		HS	6306 ZZ	6205 ZZ
		N	6206 ZZ	6206 ZZ
	132	H	6208 ZZ	6208 ZZ
		HS	6208 ZZ	6206 ZZ
	160	H	6309 ZZ	6209 ZZ
HS		6309 ZZ	6208 ZZ	
180	H	6310 ZZ	6310 ZZ	
	HS	6310 ZZ	6209 ZZ	
200	H	6312 ZZ	6310 ZZ	
225	E	6313 ZZ	6313 ZZ	
250*	E	6315 ZZ	6312 ZZ	

\* Lubricated Bearing

			DE	NDE
<b>CAST IRON BODY</b>	80	HG	6204 ZZ	6204 ZZ
	90	HG	6305 ZZ	6205 ZZ
	100	HG	6306 ZZ	6306 ZZ
	112	HG	6306 ZZ	6306 ZZ
		HSG	6306 ZZ	6306 ZZ
	132	HG	6308 ZZ	6308 ZZ
		HSG	6308 ZZ	6306 ZZ
	160	HG	6309 ZZ	6309 ZZ
		HSG	6309 ZZ	6309 ZZ
	180	HG	6310 ZZ	6310 ZZ
		HSG	6310 ZZ	6310 ZZ
	200	HG	6312 ZZ	6310 ZZ
	225	HG	6313 ZZ	6313 ZZ
	250	HG	6315 ZZ	6313 ZZ
	250*	HG*	6314	6314
	280	HG-2P	6314	6314
HG-4P-6P		6317	6317	
315	HG -2P	6316	6316	
	HG-4P-6P	6319	6319	

\* Lubricated Bearing

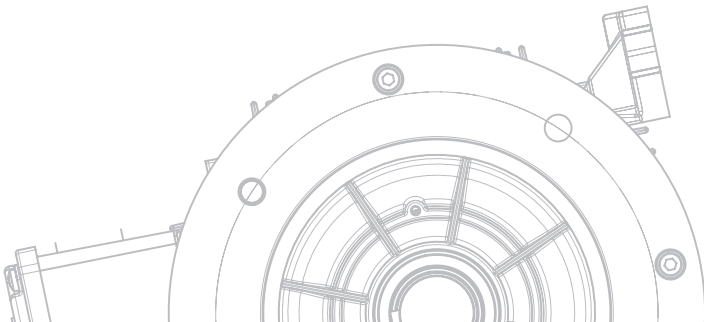

# 11

## Spare Part

The warranty becomes void if any part, such as a flange, fan, or fan cover, is removed or replaced during the disassembly process of the motor purchased.

### **WAT MOTOR SANAYİ VE TİCARET A.Ş.**

**Address:** Çerkezköy Organize Sanayi Bölgesi, Karaağaç Mah.  
8.Sokak No:4 A/2, 59510, Kapaklı / TEKİRDAĞ

**Tel** : +90 850 399 49 28

**E-mail** : support@wat.com.tr

**Web** : www.tee.com.tr - www.wat.com.tr

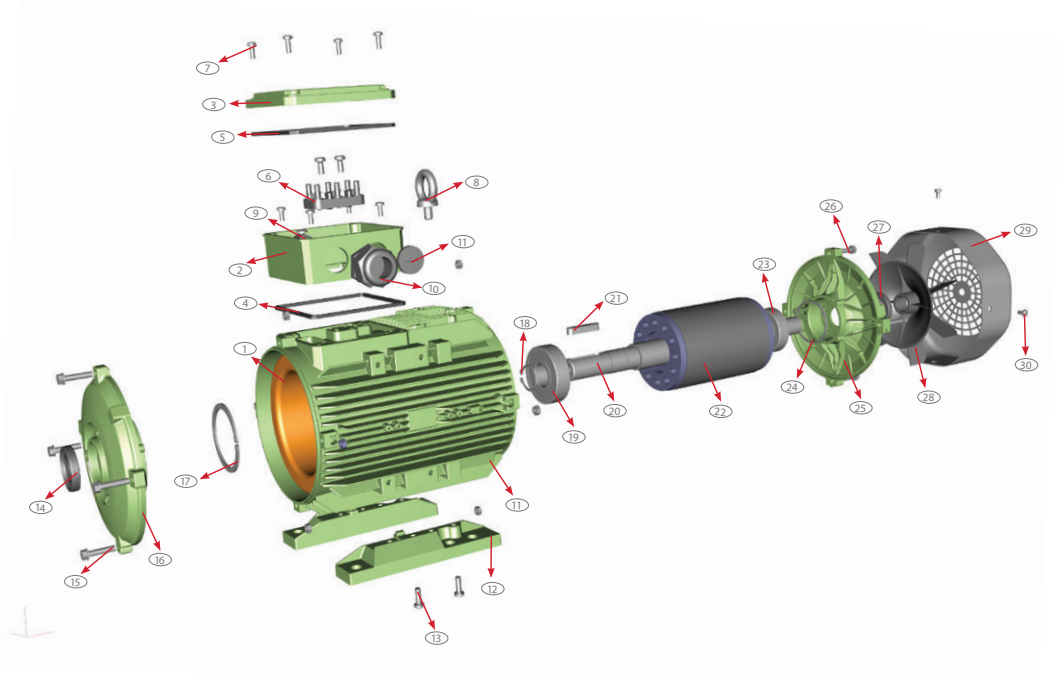

- |                                       |   |
|---------------------------------------|---|
| <b>1.</b> Wound Stator                | <b>17.</b> Snap Ring (Cover)                          |
| <b>2.</b> Terminal box                | <b>18.</b> Snap Ring (Shaft)                          |
| <b>3.</b> Terminal box cover          | <b>19.</b> Bearing (Pulley Side)                      |
| <b>4.</b> Terminal box gasket         | <b>20.</b> Shaft                                      |
| <b>5.</b> Terminal box cover gasket   | <b>21.</b> Key  |
| <b>6.</b> Terminal plate              | <b>22.</b> Rotor                                      |
| <b>7.</b> Terminal box screws         | <b>23.</b> Bearing (Opposite of the Pulley Side)      |
| <b>8.</b> Snag ring                   | <b>24.</b> Bearing tension spring                     |
| <b>9.</b> Grounding screw             | <b>25.</b> Cover (Opposite of the Pulley Side)        |
| <b>10.</b> Cable Gland                | <b>26.</b> Cover screws (Opposite of the Pulley Side) |
| <b>11.</b> Blind plug                 | <b>27.</b> Seal (Against the Pulley Side)             |
| <b>12.</b> Foot                       | <b>28.</b> Fan  |
| <b>13.</b> Foot screws                | <b>29.</b> Fan Cover                                  |
| <b>14.</b> Seal (Pulley Side)         | <b>30.</b> Fan cover screws                           |
| <b>15.</b> Cover screws (Pulley Side) |   |
| <b>16.</b> Cover [Pulley side]        |   |

# 12

## Customer Service and Support

Dear Customer,  
We believe in the importance of providing good service as well as offering you good products. Accordingly, we continue to offer you, as our knowledgeable consumers, a wide range of new services.

Our Authorized Service Centers are now providing service 5 days a week from 8:00 to 18:00. You can contact WAT Electric Motors Customer Service Hotline by dialing this number directly and request the service you require.



**Customer Services Department**  
**Tel: +90 850 399 4928**

We kindly request that you comply with the following recommendations.

- When you receive your product, please have the Warranty Certificate approved by your Authorized Dealer.
- Use your product in accordance with the principles of the operating manual.
- If you have a request for service regarding your product, please contact Customer Service using the phone numbers above.
- Service Life: 10 years. (The spare parts necessary for the product to function will be available for this period.)

***WAT electric motors are under warranty for 2 years against manufacturing defects.***

### **SERVICE CONTACT INFORMATION**

#### **Factory/Customer Services Department**

WAT Motor Sanayi ve Ticaret A.Ş., Organize Sanayi Bölgesi Karaağaç Mah. 8.Sokak  
No:4 A/2, 59510 Kapaklı / TEKİRDAĞ

**Tel: (0-282) 292 22 69**

**Fax: (0-282) 292 22 23**

**E-mail: support@wat.com.tr**

**Web: www.tee.com.tr - www.wat.com.tr**

*Our Authorized Service Stations are registered in the Service Information System (www.servis.gov.tr) established by the Ministry of Trade.*

*You can find the current contact information for our authorized services and spare parts dealers on our website.*



## *The Issues Consumers Should Pay Attention Regarding Warranty*

*This warranty provided by WAT Motor Industry and Trade Inc. does not cover the repair of faults arising from the abnormal use of the electric motor, and the following cases are also excluded from the warranty.*

- 1. Damages and failures resulting from misuse,*
- 2. Damages and failures that occur during loading, unloading, and transportation after the product is delivered to the customer,*
- 3. Damages and failures caused by voltage drops or surges, faulty electrical installations, or operation at a voltage different from the voltage specified on the rating plate of the product,*
- 4. Failures and damages caused by fire and lightning strikes,*
- 5. Failures resulting from use of the Product in violation of the instructions provided in the operating manual.*

*The warranty granted for the product shall be void if unauthorized persons tamper with the product.*

*The malfunctions stated above are repaired against a fee.*

*The installation and transportation of the product to its place of operation are not included in the product price.*

*The responsibility for completing and submitting the warranty certificate to the consumer lies with the seller, dealer, agent, or representative from whom the consumer purchased the goods. This warranty is void if the warranty certificate is damaged, the original serial number on the product is removed or damaged.*

*The CE conformity assessment of your product has been carried out at the facilities of WAT Motor Sanayi ve Ticaret A.Ş.*

**Address:** WAT Motor Sanayi ve Ticaret A.Ş. Organize Sanayi Bölgesi Karaağaç Mahallesi, 8. Sokak, No: 4 A/2 Kapaklı 59510 Tekirdağ-TÜRKİYE

**Customer Services Department:** +90 850 399 4928 / +90 282 292 2269



## Electric Motor WARRANTY CERTIFICATE

The WAT Electric Motor, including all its components, is guaranteed against defects in material, workmanship, and manufacturing, provided that it is used as specified in the operating manual and has not been serviced, repaired, or otherwise interfered with for maintenance, repair, or any other reason by persons other than those authorized by WAT Motor Sanayi ve Ticaret A.Ş. **IS GUARANTEED FOR A PERIOD OF 2 (TWO) YEARS.** In the event that the product malfunctions within the cover of warranty period due to both material and workmanship and assembly errors, no labour costs, replacement part fees, or other charges will be applied for the repairs performed. The time taken for repairs carried out within the warranty period shall be added to the warranty period. The repair period is maximum 20 work days. This period begins on the date the product is reported to our authorized service workshop, or if we do not have authorized service workshops in the region, to our Authorized Dealers or our Company. If the defect in the product cannot be repaired within 10 business days, WAT Motor Sanayi ve Ticaret A.Ş. shall assign another product with similar features to the customer for use until the repair of the product is completed.

The determination of the technical methods to be applied to resolve the malfunction and the determination of the parts to be replaced are entirely the responsibility of our company. The repair of the fault can be carried out at the location where the product is located or at Authorized Service Workshops. Our customer's approval is required for this purpose.

However;

Despite the consumer has exercised his/her right to repair the goods, in case;

1. Within one year from the date of delivery to the consumer, provided that it remains within the warranty period, if the product malfunctions at least four times or six times within the warranty period specified by the manufacturer and/or importer, and if these malfunctions prevent the continuous use of the product,
2. The maximum term necessary to repair is exceeded,
3. The service station of the company, and in case the service station is not available, the seller, dealer, agent, representative, importer or one of the manufacturer-producer of the goods determines that the repair of the malfunctioning is not possible, the consumer may request free replacement of the goods, reimbursement or price reduction.

For any issues that may arise regarding the warranty certificate, you may apply to the Directorate of Consumer Protection and Market Surveillance of the Ministry of Customs and Trade of the Republic of Turkey. The use of this Warranty Certificate has been authorized by the Directorate General for Consumer Protection and Market Surveillance of the Ministry of Customs and Trade of the Republic of Turkey, in accordance with Law No. 4077 on the Protection of Consumers and the Regulation on the Implementation Principles of the Warranty Certificate enacted based on this Law.

### WAT MOTOR SANAYİ VE TİCARET A.Ş. GENERAL MANAGER

Serial No.:

Type:

Date and Location of Delivery:

Invoice Date, No:

Seller Company Name:

Address:

Tel-Fax:

Seller Company Name (Stamp and Signature)

This document has been issued in accordance with the Directorate of Consumer Protection and Market Surveillance of the Ministry of Customs and Trade, document number 10934, dated August 22, 2013.

**This part to be signed and stamped by the Authorized Dealer.**



## **BRAKED MOTORS**

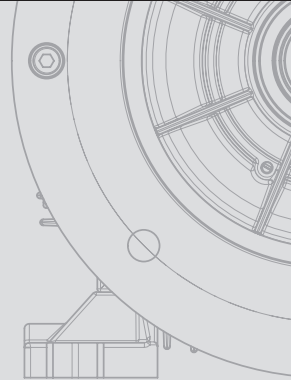

# BRAKED MOTORS MAINTENANCE, INSTALLATION, AND OPERATION INSTRUCTIONS

WAT Motor Brake Kits are designed to be easily installed on WAT motors manufactured as Brake-Ready.

Select the appropriate brake kit based on the motor's rated power and kW - Power rate.

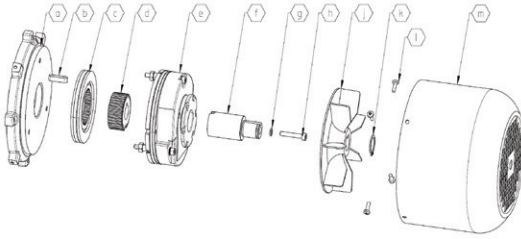

- a- BRAKE COVER
- b- KEY
- c- BRAKE GEAR
- d- BRAKE PAD
- e- FAN CONNECTION PART
- f- SPRING-LOADED PULLEY
- g- BOLT
- h- BRAKE
- j- FAN
- k- SNAP RING
- l- FAN COVER
- m- FAN COVER SCREW

## PREPARING THE MOTOR FOR THE BRAKE CONNECTION

Procedure;

1. Remove the fan cover screws.
2. Remove the fan cover.
3. Remove the safety ring using a tool.
4. Remove the fan and set it aside for later use.
5. Remove the motor cover mounting equipment and set them aside.
6. Remove the cover.

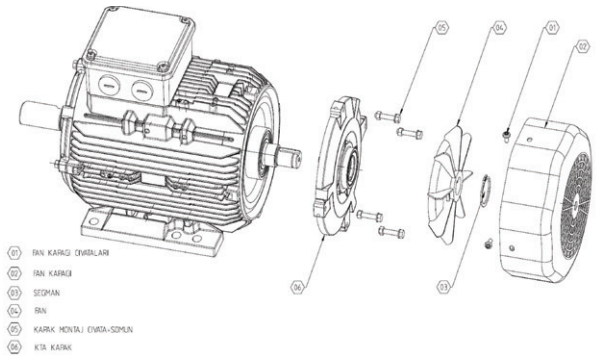

- 01 FAN KAPAKI ÇEVRELEMLERİ
- 02 FAN KAPAKI
- 03 FAN
- 04 SEĞİMAN
- 05 FAN
- 06 KARK MENTALI EMİSA-SİPLEN
- 07 KİTİ KARKI

# BRAKE INSTALLATION

- Replace the rear motor cover with the brake cover. (a)
- Drive the key included in the kit into the keyway of the motor shaft. (b) Install the brake hub gear onto the rotor shaft. (d)
- Attach the brake pad to the brake drum. (c)
- Install the extension piece onto the rotor shaft with the bolt and nut, centering it with the key. (f,g,h) Install the brake onto the mounting holes in the brake cover. (e)
- Perform the brake torque adjustments.
- Install the fan onto the extension piece and secure it with the snap ring. (j,k)
- Install the fan cover onto the brake cover using screws.. (m,l)

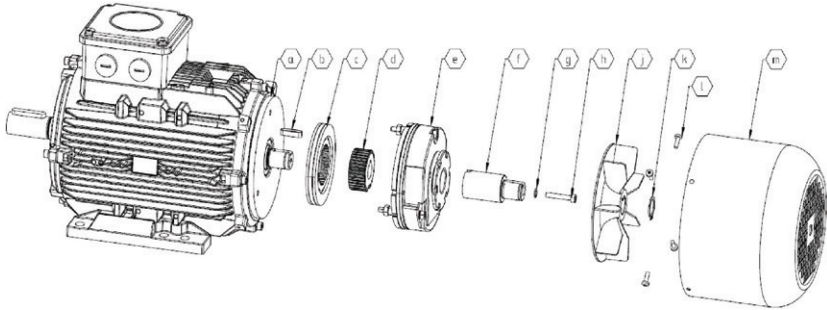

# GENERAL SAFETY INSTRUCTIONS

## TECHNICAL DATA



**SUPPLY VOLTAGE**

The supply voltage of the brake may vary by  $\pm 6\%$  with respect to the nominal voltage. The supply voltage is printed on the rating plate. The electromagnet requires a voltage close to its nominal rating; low voltage may cause the brake to malfunction.



**ROOM TEMPERATURE**

The brake is designed to operate between 5°C and 40°C.

## STATIC TORQUE VALUES



**BRAKE TEST OPERATION**

Without testing, the torque value of the brake applied during braking may be reduced by 20% (with standard friction material). With anti-skid, the reduction may be up to 30%. Always operate the brake before using it.

## INSTALLATION, SETUP AND SERVICE



**DISCONNECT THE BRAKE**

Maintenance and adjustment procedures, and brake disassembly shall be performed after disconnecting the electrical connections.

- The responsibility for brake functionality depends entirely on the installation method.
- The brake/rectifier supply shall be carried out according to the data on the rating plate.
- The brake connection inside the terminal box shall be made correctly.
- Check if the correct brake kit is installed.
- Check if the brake torque meets the application requirements.
- Installation shall be performed using the correct equipment. (Filler knife, snap-ring pliers, Allen wrench)
- Proper operation of the brakes depends on regular maintenance.

## PERIODIC MAINTENANCE OF BRAKE MOTORS

### BRAKE:

Normal brake operation is guaranteed only at room temperature.

When the brakes are not operated for a long period in cold and damp conditions, the brake pads shall be covered to prevent them from sticking to the friction surface.

**The minimum braking torque setting shall always be at least 30% of the normal value.** The desired performance of the brake mechanism may only be achieved by using original parts. The wear that will occur on the brake pads over time varies depending on the inertia of the motor and load, the braking speed, the frequency of use, and the heating of the brakes. Always replace the brake pads after 3mm of wear on the brake pad material. Make sure to readjust the air gap after replacing the brake pads. When the air gap reaches 0.7mm, the air gap shall be adjusted again to ensure the desired performance. The adjustment of the air gap is performed by turning the adjustment screws after removing the mounting screws.

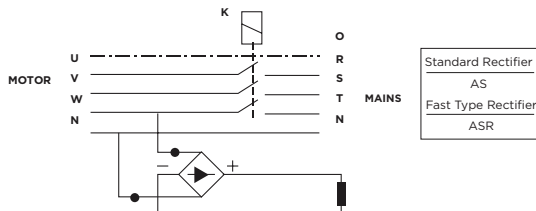
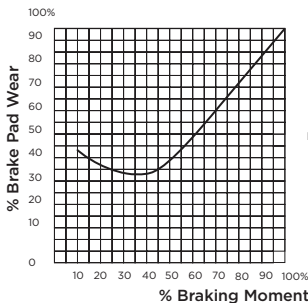

If you need to adjust the air gap after the brake has been applied for a certain period of time, allow the brake to cool down. The normal value for the air gap is 0.2mm (+0.05-0). The maximum permissible air gap value is 0.7 mm. If this value is exceeded, braking performance may be affected, braking may not be fully effective, and the motor and brakes may overheat. The higher the braking torque applied, the greater the corresponding increase in brake pad wear. 100V DC motors with brakes are equipped with a half-wave rectifier and shall be connected according to the following diagram for normal braking function. The rectifiers required for 24V DC brake motors shall be procured by the customer.

### Brake Torque Setting

Braking torque may be adjusted by changing the distance A. Wear on the friction material will also vary depending on changes in the braking torque.

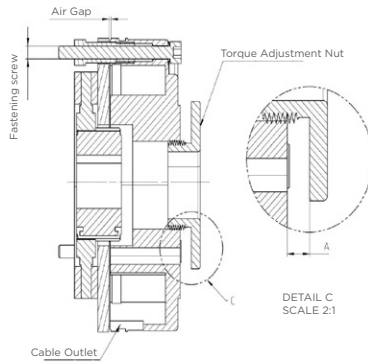

Brake Type	Ideal Air Gap "t" (mm) (min. and max.)	
K01-100V	0,15	0,5
K02-100V	0,2	0,6
K03-100V	0,2	0,6
K04-100V	0,2	0,7
K05-100V	0,2	0,7
K06-100V	0,2	0,7

The brake air gap is adjusted using a go/no-go gauge according to the specified values. Finally, the torque adjustment nut located on the rear of the brake is tightened to the specified measurement according to the desired torque value.

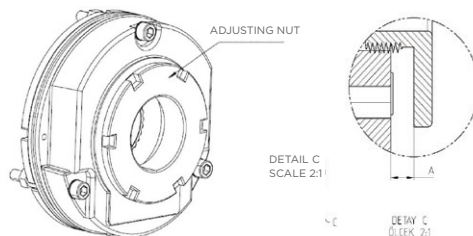

		K1 A(mm) Nm	K2 A(mm) Nm	K3 A(mm) Nm	K4 A(mm) Nm	K5 A(mm) Nm	K6 A(mm) Nm	K7 A(mm) Nm	K7/D A(mm) Nm	K8 A(mm) Nm	K8/D A(mm) Nm	K9 A(mm) Nm	K9/D A(mm) Nm
100%		5,2	4,6	4,6	5,9	8,2	8,2	8,2	8,2	8,2	8,2	8,2	8,2
		5	12	16	20	40	60	90	180	200	400	300	600
75%	MAX.	6,9 3,75	6,1 9	6,2 15	7,1 15	10,7 30	10,3 45	9,9 67,5	9,9 135	9,7 150	9,7 300	10,7 225	10,7 450
50%		8,7 2,5	7,6 6	7,6 8	8,5 10	13,2 20	12,5 30	11,7 45	11,7 90	11,2 100	11,2 200	13,2 150	13,2 300

After the installation of the brake kit, changes in the motor's noise and vibration levels may be observed.

### Electrical Connection Options for Brake Motors

#### AC SWITCHING

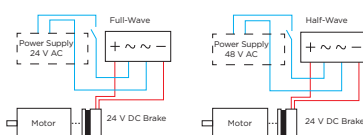
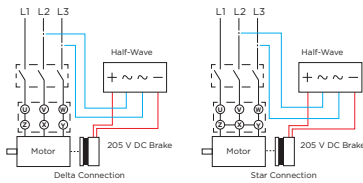
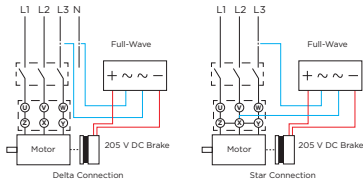
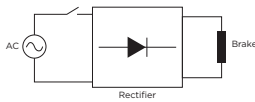

#### DC SWITCHING

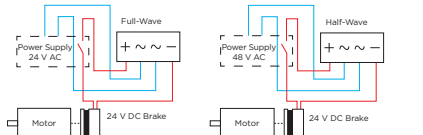
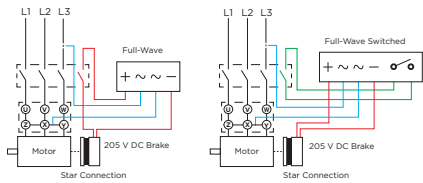
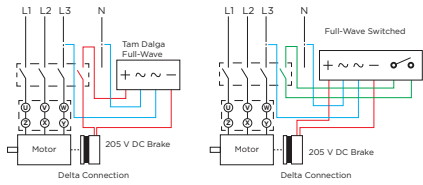
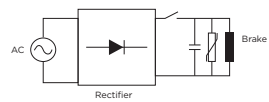

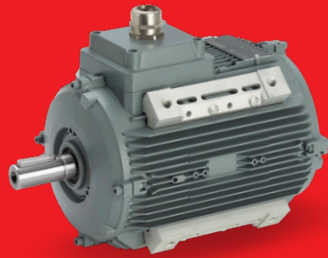

# SMOKE EXTRACTION MOTORS

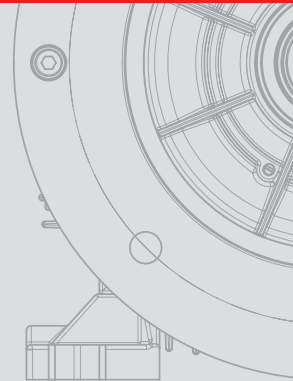

# INSTALLATION, OPERATION, MAINTENANCE AND SAFETY GUIDE

**WAT MOTOR F300 & F400 – 2 Hours Smoke Extraction motors**  
**Installation, Operation, Maintenance and Safety Manual**

## 1. SAFETY INFORMATION

Follow these instructions to ensure the safe and proper installation, operation, and maintenance of WAT F300 Aluminum Body and F400 Cast Iron Body Smoke Extraction Motors. This manual shall be made available to all persons who install, operate, or maintain the motor or related equipment, including fans, OEMs, and end users. The motor shall be installed and operated by qualified personnel who are familiar with health and safety requirements and the applicable national regulations. Failure to follow these instructions may render all applicable warranties void. Operation by unauthorized persons may result in serious injury and property damage.



**PLEASE READ THE USER MANUAL CAREFULLY BEFORE OPERATING THE MOTORS. PLEASE OBSERVE AND FOLLOW THE SAFETY INSTRUCTIONS.**

This operating manual will help you use your electric motor safely.

- Before installing and starting your motor, please read the user manual and other documents provided with the machine carefully.
- Please follow the safety instructions.
- Please keep the operating manual in an easily accessible place for future reference.



### **WARNING**

This symbol indicates a warning against the risk of injury or damage. Please be careful and follow the safety instructions.



### **ELECTRICAL HAZARD**

This symbol indicates the risk of electric shock. This is a warning against electrical voltage.



### **NOTE**

This symbol indicates important information related to the subject.

- Follow the technical information in the catalogues and the on the electric motors. Carefully review the operating instructions.
- The startup and shutdown procedures according to the electrical connection diagrams shall only be performed by authorized operators.
- The operation, maintenance, and any intervention in case of malfunction of electric motors shall be performed only by authorized operators.
- Before starting any maintenance work on an electric motor, the power supply to the motor shall be disconnected and the motor shall be secured with warning signs to maintain safety.
- After disconnecting the power supply to the motor, the operator shall wait until all moving parts have come to a complete stop before making any operation on the motor.
- Inspect the electrical and mechanical connections before reconnecting the electrical connections of the motor. Provide proper grounding.
- Tighten electrical terminal connections with the appropriate torque to ensure the connection does not cause problems.
- Parts that are energized or rotating and that can generate high temperatures are present in this type of equipment during operation. Thus, exposed terminal boxes, unprotected couplings, and improper operation can cause serious injury and/or damage to property.
- Persons responsible for installation safety shall ensure the following:
- Only qualified personnel may perform the installation and operation services for the equipment;
- This personnel shall carry this manual along with other documents provided with the motor, and work shall be performed in accordance with the standards and documents specific to this product.
- Unqualified personnel shall never perform any work on electrical equipment;
- Warranty may become void if installation and safety instructions are not followed properly.

### **Qualified personnel shall ensure the following:**

- Technical data regarding permitted applications (assembly, storage, connection, installation, and operating conditions) included in this Manual, Purchase Order documents, operating instructions, manuals, and other documents;
- Instructions and special conditions for installation on site;
- Use of suitable tools and equipment;
- Points to be considered during use and transport;
- Removal of all protective devices from each component before installation;

- Avoiding lifting and carrying operations outside the points specified in this manual;
- Furthermore, all motors shall be stored in vibration-free rooms to prevent damage to the bearings. For practical reasons, it is not possible to include detailed information covering all construction variables or all possible assembly, operation, or maintenance alternatives in this manual. Please contact WAT directly for clarification if you have any questions or concerns.

## 2. INSULATION RESISTANCE

Measure the insulation resistance of motors stored for extended periods before shipping. If the windings are damaged due to moisture during storage, measure the insulation resistance and make a decision about the motor according to the following table:

If it is 2 M $\Omega$  or less, it shall be inspected by the motor service operator.

If it is between 2 M $\Omega$  and 100 M $\Omega$ , the motor is hazardous.

If it is 100 M $\Omega$  or above, the motor is suitable.

- > There is a risk of electric shock when operating an electric motor with an improper insulation resistance. The motor shall not be started if its measured insulation resistance is low.
- > Ensure that the power is turned off and the motor is not running before measuring the insulation resistance.. The body of the motor and any thermal protectors shall be grounded.
- > Disconnect the motor from its power supply before performing any insulation measurements.. Discharge the terminals immediately after taking the measurement to prevent any risk of electrical discharge. Do not touch the terminals during measurement and immediately after measurement, as they may still carry a hazardous voltage. Also, if power cables are connected, make sure to disconnect the main power supply properly. This applies to both main and auxiliary circuits, and particularly to anti-condensation heating circuits.
- > Be careful when lifting to measure insulation resistance:  
Do not lift the motor by its shaft;  
Check the weight of the motor to be lifted.

### 3. INSTALLATION OF THE MOTOR AND MECHANICAL CONNECTIONS

#### Before Installation

- Ensure that the motor is not damaged during transportation and storage.
- Check whether the information on the motor 's rating plate is consistent with the current line voltage.
- Check if the motor is suitable for its intended use.
- Check that the accessories (if any) of the motor are complete and in operational condition.

#### Preparation for Installation

- Remove the rust inhibitor on the shaft using a suitable agent.
- Check for friction by rotating the motor shaft by hand.
- Measure the insulation resistance.

WAT Motors are dynamically balanced by installing half keys. Therefore, the transmission elements shall be balanced with a half-key.

#### Installation

- The motor shall be mounted on a flat surface with a vibration damper and in a location resistant to torsion.
- The load and motor shaft shall be on the same axis and parallel to each other.
- The air intake of the motor shall be adequately open.
- The terminal box and cover for the electrical connections shall be easily accessible after installation.

If motors are connected by couplings and similar components, parallelism and axial concentricity are critical for the performance and service life of the motor. Therefore, it shall be properly aligned and measured. Vibration may occur in the motor if the alignment is not correct. Some parts may be damaged if the eccentricity is too high.

In belt and pulley applications, pulleys shall be positioned parallel to each other, and the belt and pulley system shall be adjusted with appropriate belts at the correct tension. Excessive tension in the belts may result in excessive vibration and also cause breakage of the shaft or damage to the bearings. As the motor is balanced with a half key, the pulleys and couplings to be used shall also be balanced with a half key.

The ventilation of the electric motor at the installation site shall not be obstructed. There shall be sufficient space behind the motor fan to allow for suction. The motor shall be installed in a way that allows for electrical connections and maintenance. In case of the presence of airborne dust in the environment, the resulting change and drop in the airflow created by the fan will result in a decrease in cooling performance.

Installation sites shall allow easy access for inspection and maintenance services. WAT is not responsible for bringing motors to the assembly area or removing them from the site.

The cable glands supplied with the motor shall be installed to protect the phase connection cables. In general, do not lift the motor by its cable or hose assembly to prevent damage to the insulation on the cables and hoses.

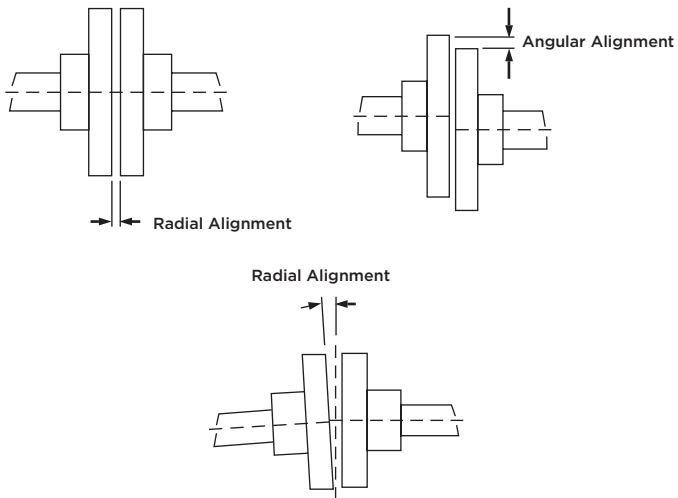

## 4. COOLING

Smoke Extraction Motors are designed to operate at a maximum ambient temperature of 40°C and at a maximum altitude of 1000 meters above sea level.

Ensure that no equipment, surface, or direct sunlight nearby radiates additional heat to the motor. To allow free air circulation around the motor, TEFC (Totally Enclosed Fan-Cooled) machines shall not be mounted closer than 1/4 of the air inlet diameter to the walls or other obstacles.

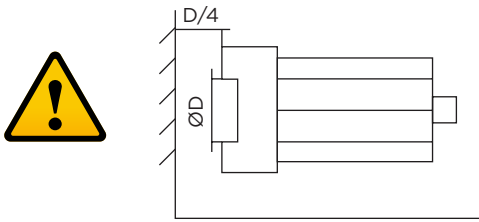

The distance to the nearest object on the air intake side of the motor shall be at least one-fourth of the fan cover hole diameter.

WAT F300 Smoke Extraction Motors are designed and approved to operate with the IC 418, TEAO cooling method. The fans shall provide adequate airflow for the motor to perform the desired operation when in blowing or suction mode. Otherwise, it cannot provide min. fan system airflow; increased temperature may cause overheating and motor failure.

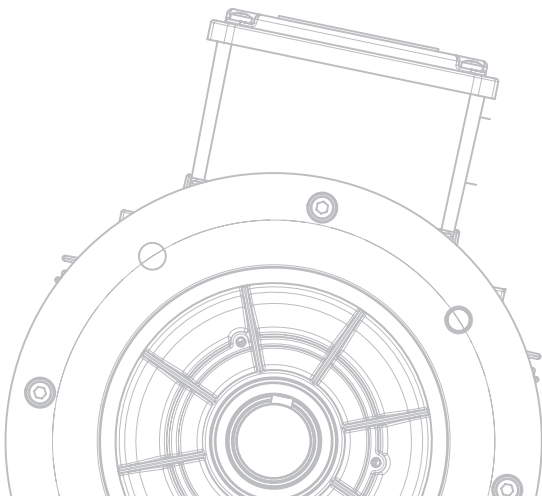

## 5. ELECTRICAL CONNECTIONS AND GROUNDING

### Before Installation

- The connections shall be made according to the electrical connection diagram provided with the motor. Do not connect the motor without checking the diagram.
- Examine the voltage and frequency information on the rating plate of the motor carefully and check that it is suitable for the power line.

### Preparation for Installation

- Check for corrosion on the connection side of the cables to the windings.
- The cross-section of the cables used and the distance to the motor control panel shall be appropriate for the motor power. (In case the loose cable extensions are not long enough)
- The suitability of the cable glands in the terminal box shall be inspected according to the cable diameter to be used.
- Determine the rotation direction before connecting the motor to the load, and then connect it after ensuring compatibility with the load.

### Connection Diagram for Single Speed Motors with Winding

#### 3-Phase, Single Speed

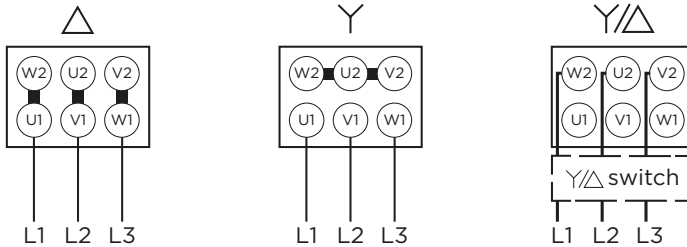

### Starting with direct start

The simplest way to start a squirrel cage asynchronous motor is to connect the mains supply directly to the motor. The only equipment required for starting is a direct online starter. While this is the most preferred method, current limitations and regulations shall be observed due to the high starting current.

## Star/Delta (Y/Δ) Starting

If the starting current of the motor exceeds the power supply limit, Y/Δ starting can be used. A motor with a 380 or 400V (Δ) winding is started with the winding connected in Y. This method reduces the starting current and torque to approximately one-third of the starting value. In order to limit current and torque fluctuations during the switch from Y to Δ, the switching operation shall be performed when the motor approaches its nominal speed as much as possible (93-95%).

## Connection Diagram for Dual Speed Motors with Winding

### Winding Connection Diagram for Dahlander Motors

Dahlander motors are designed to operate in different modes depending on torque and power requirements. These are fixed torque, fixed power, and variable torque. Variable torque operating mode is commonly preferred in fan applications where F300 and F400 Dahlander motors are used. The terminal connections for these Y/YY-connected motors shall be made as follows.

Low Speed Connection - Star Series (Y)

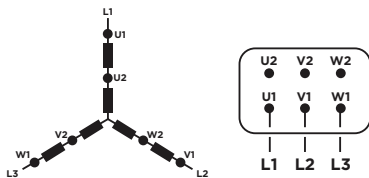

High Speed Connection - Parallel Star (YY)

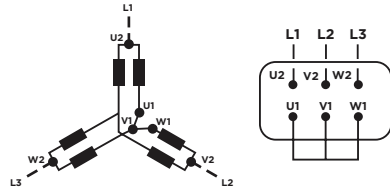

All motors are capable of running in both directions of rotation. If power supply phase conductors, viewed from the driver side: are connected to terminals L1, L2, L3, U1, V1, W1, the motor will rotate clockwise. If the connections of any two terminals are reversed, the motor will rotate counterclockwise. Before connecting the motor, quickly turn it ON/OFF to check the rotation direction.



**The motor shall be connected to a proper grounding system. Thermal protection is not available as standard on smoke extraction motors.**

- » All WAT F300 & F400 smoke extraction motors are supplied with ZZ sealed bearings. The bearings are filled with DuPont Krytox GPL 226 bearing grease, which is resistant to high temperatures. Use equivalent bearing grease if the bearing needs to be replaced during operation.
- » WAT F300 & F400 smoke extraction motors are not supplied with any kind of thermal protector. If external protectors are connected through the operating system, please ensure that this will not adversely affect the operations of the motor during fire mode.
- » Please check that the motor is running without load. Is it rotating freely without abnormal noise? Is the direction of rotation correct? (Reverse either terminal of the power source to reverse the direction of rotation).
- » Please check the following;
  - » Is the air flowing through the motor at the recommended speed?
  - » **Visual inspection:** Cleanliness in the working area, terminal box, cables, terminals, stud bolts, fan and fan cover, couplings, connecting parts, and drain plug.
  - » **Alignment type:** Which type used? (clock - radial/radial; clock - radial/axial; optical; rule based on rollers)
  - » **Alignment values:** Radial (....mm) and axial (....mm).
  - » **Starting type:** DOL, Soft Starter, frequency inverter, etc. (Model, capacity, etc.)
  - » **Voltage:** Measure the voltages between phases and check the tolerance according to IEC60034-1.
  - » **Voltage Unbalance:** Calculate the voltage imbalance as per IEC60034-26 and check if there is a problem;.
  - » **Current:** Check the current in each phase and compare it with the current on the rating plate.

- » **Current Unbalance:** Calculate the current imbalance as per IEC60034-26 and check if there is a problem.
- » **Speed:** Check the speed (rpm).
- » **Ambient Temperature:** Measure the ambient temperature at a distance of 1 m from the motor.
- » **Height:** Determine the field height.
- » **Air flow rate:** Check if the TEAO motor is receiving the required air flow rate as recommended.
- » **Bearing housing temperature:** DE and NDE temperature.
- » **Winding temperature:** Check if the winding temperature is in compliance with the insulation class limit.
- » **Vibration values:** As recommended by standard practice, check the vibration at all 6 points on the DE and NDE bearings (if possible). Also check the acceleration.
- » **Final condition:** Whether it has been approved or not and who approved it.

**General observation:** All details that were verified during startup

## 6. STORAGE

If the motors are to be stored for a long period of time, they shall be stored in a dry, vibration-free, clean, well-ventilated room. Before starting the motors, check the insulation resistance and dry the windings if necessary (see the Maintenance section). The water drain holes plugged, if available, shall be located at the lowest point of the enclosure according to the construction and mounting arrangement of the motor and shall be kept clean. When these plugs are removed, the protection rating will be reduced to IP44.

To prevent migration of grease and corrosion, it is recommended that the shaft be manually rotated once a month (at least 10 turns). It is also recommended to move the shaft to another position after 10 turns.

## 7. LIFTING AND HANDLING

WAT F300 Smoke Extraction Motors are manufactured in sizes ranging from 80 to 315 Frame. Motor bodies up to 250 Frame are made of aluminum, while 280 and 315 Frame motors have cast iron bodies. All aluminum body motors feature an optional foot mount, and motors with 80, 90, and 100 bodies can be converted to the B30 - PAD Mounted option using the separately provided attachments.

WAT F400 Smoke Extraction Motors are manufactured with Cast Iron bodies, with or without legs, in sizes ranging from 80 to 315 Frame.

# F300 SERIES

## 80 ve 90 FRAME MOTORS

There are no mounting points for lifting eyes on the housing. There are 4 foot connection points that may be used as PAD mounting attachment connection points or lifting points. Two of them are marked with red arrows in the image below as a visual reference.

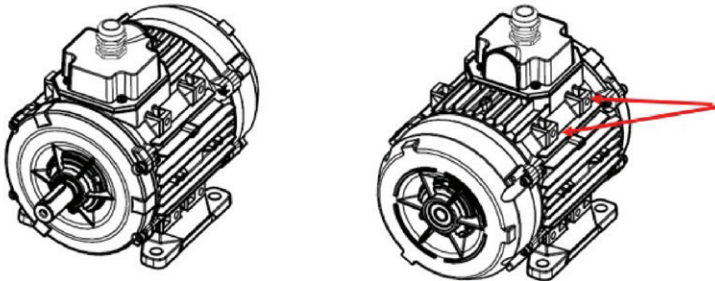

## 100 FRAME MOTORS

There is one lifting eye mounting point on the top of the housing. Similar to the previous design, the side foot connection points can be used for lifting or PAD-mounted fixture installation.

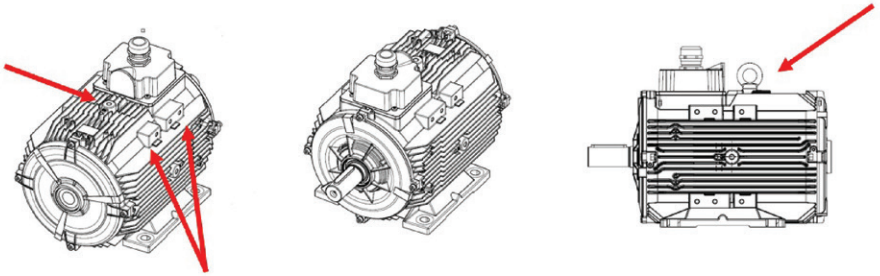

## 112-132-160 FRAME MOTORS

All three types with aluminum bodies have the same design features. There are two lifting points on the top of the housing, which are part of the aluminum body. Also, there are threaded holes suitable for the installation of lifting eyes on both sides of the body.

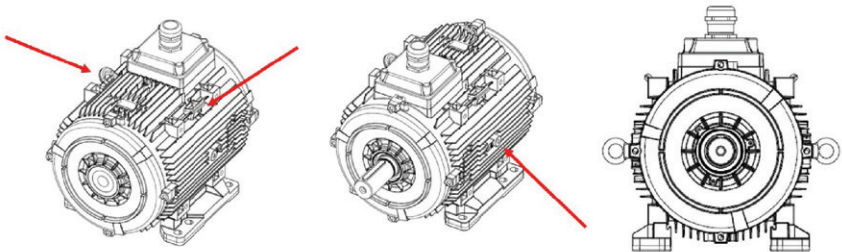

## 180 - 200 FRAME MOTORS

There are two lifting eye mounting points on the top of the housing. Also, there are two side gear holes that can be used for mounting lifting eyes.

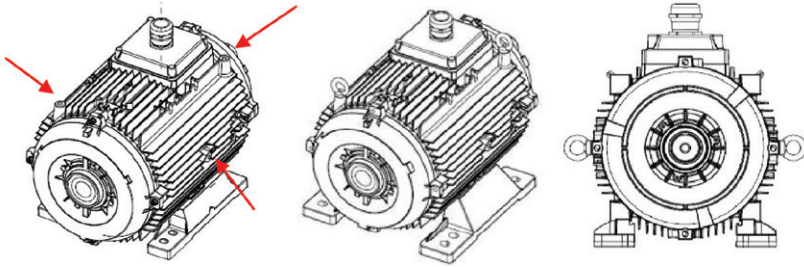

## 225-250 FRAME MOTORS

There are two lifting eye mounting points on the top of the housing. Also, there are two side gear holes that can be used for mounting lifting eyes.

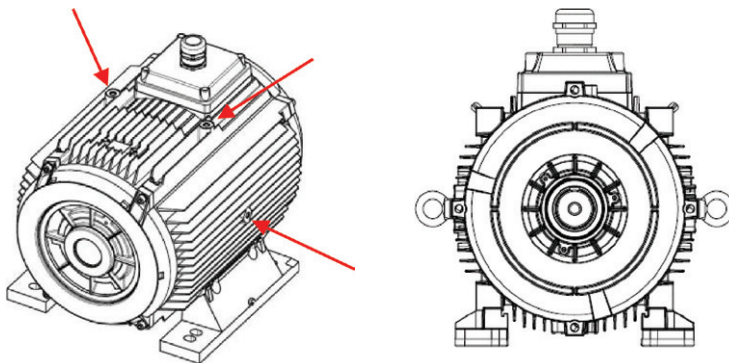

## 280- 315 FRAME MOTORS

On both sides of the housing, there are two gear holes that can be used for lifting and tilting with lifting eyes.

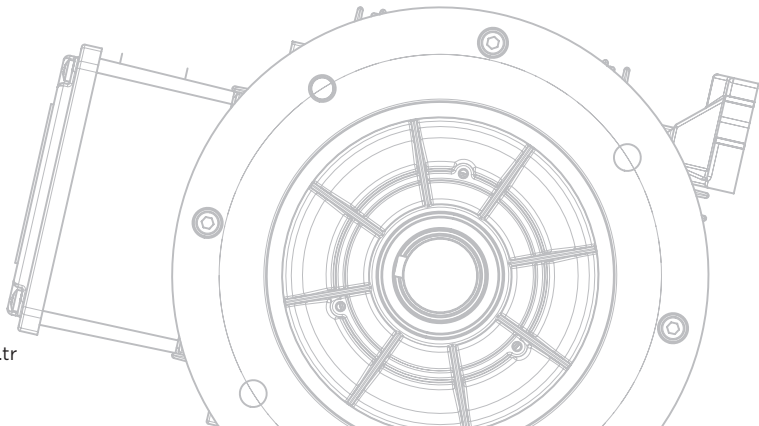
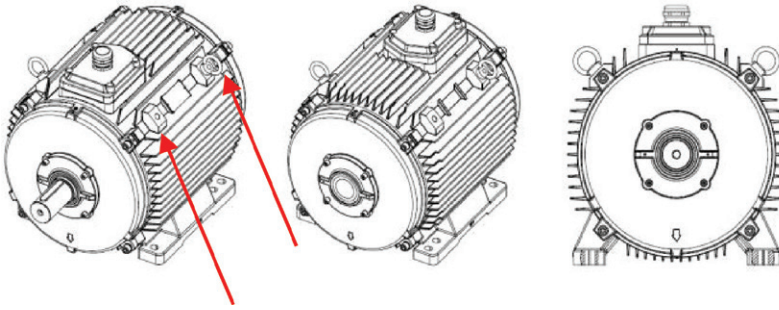

# F400 SERIES

## S3HG80 - 80 FRAME

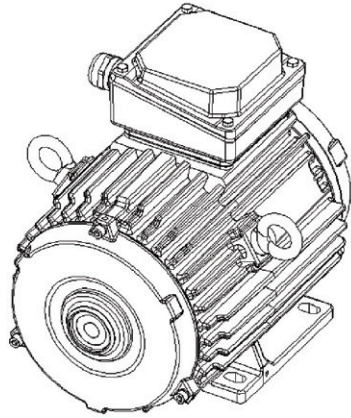
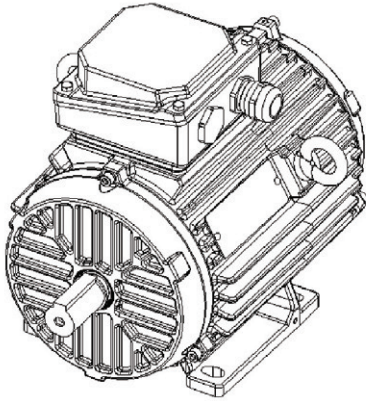

## S3HG90 - 90 FRAME

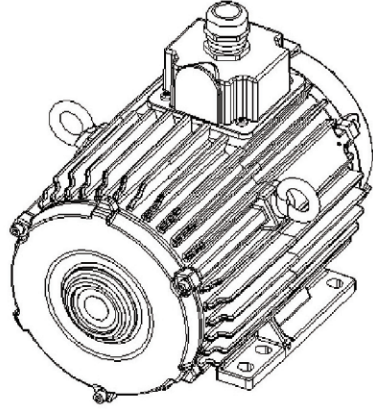
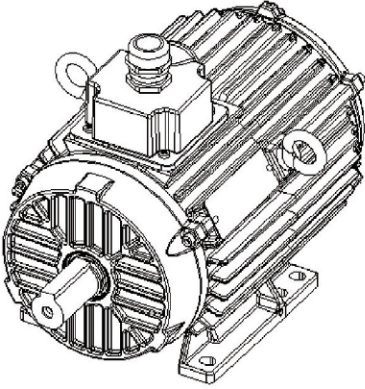

## S3HG100 - 100 FRAME

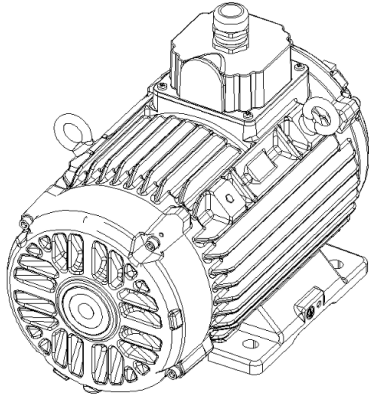
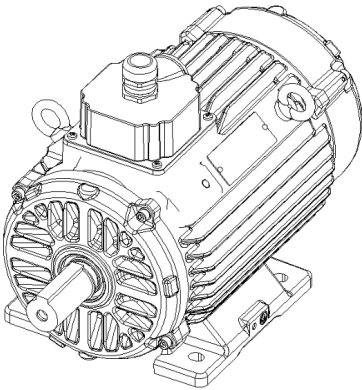

### S3HG112 - 112 FRAME

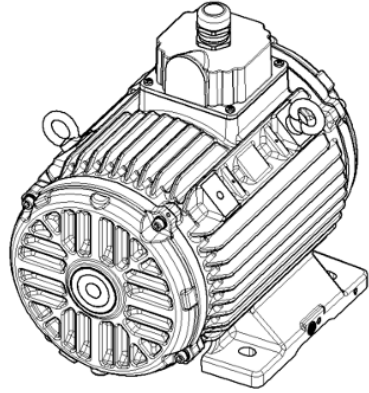
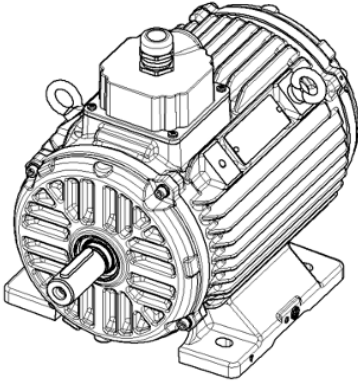

### S3HG132 - 132 FRAME

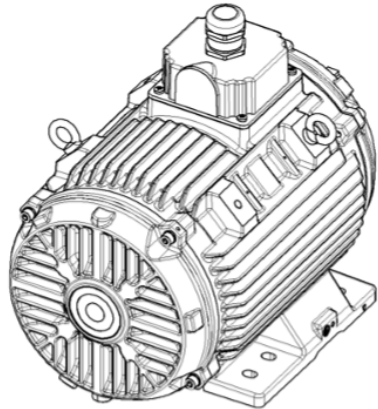
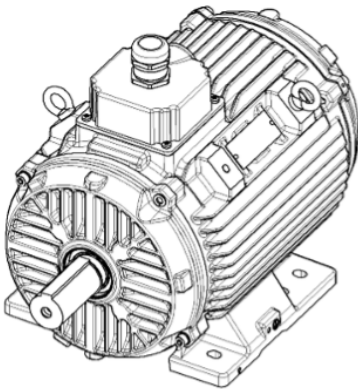

### S3HG160 - 160 FRAME

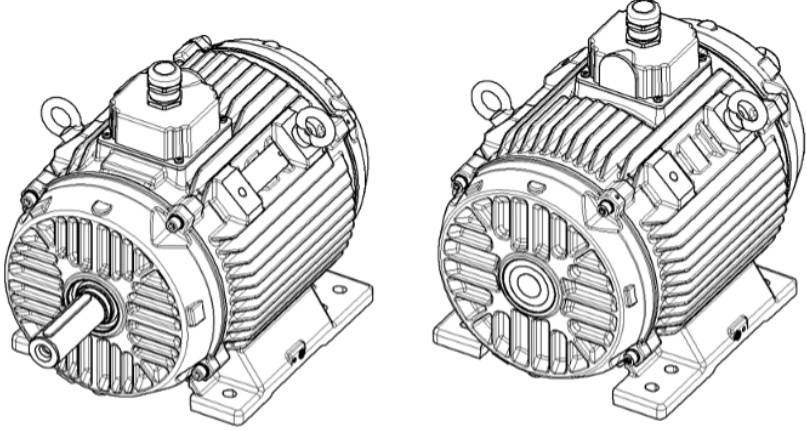

### S3HG180 - 180 FRAME

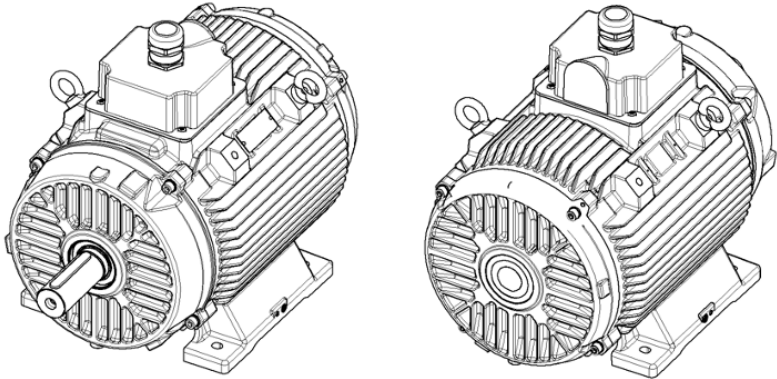

### S3HG200 - 200 FRAME

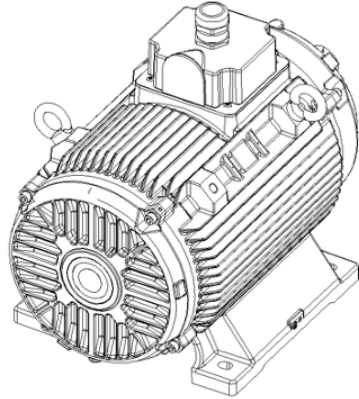
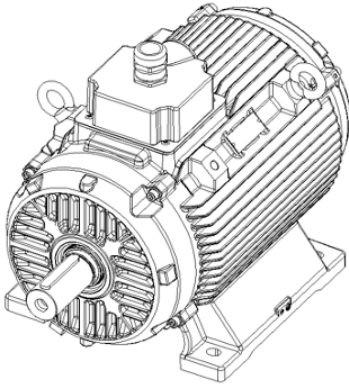

### S3HG225 - 225 FRAME

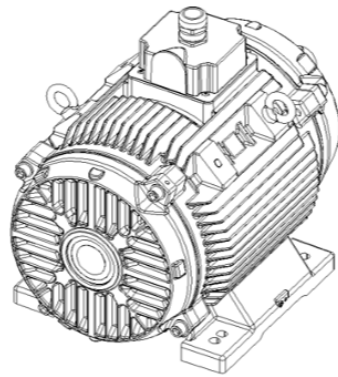
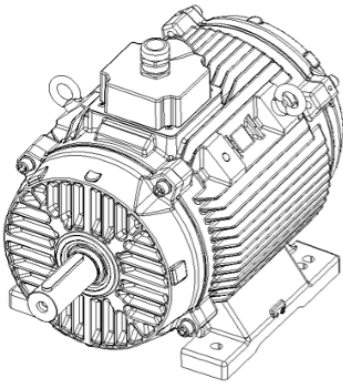

### S3HG250 - 250 FRAME

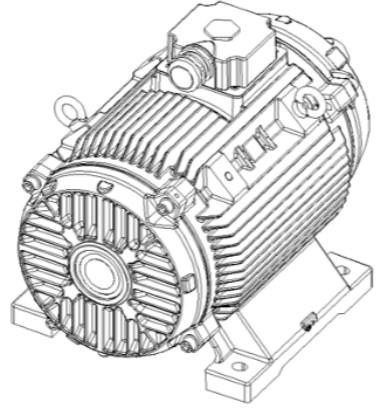
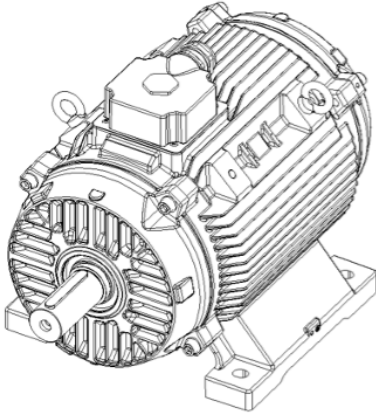

### S4HG280 - 280 FRAME

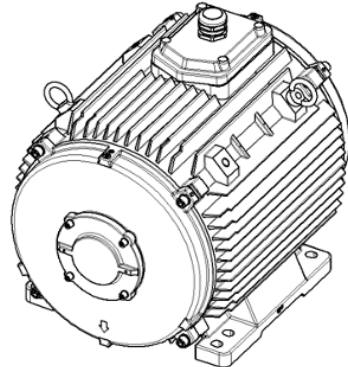
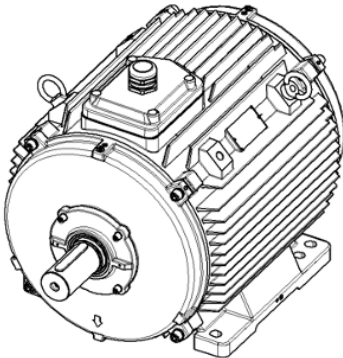

## S4HG315 - 315 FRAME

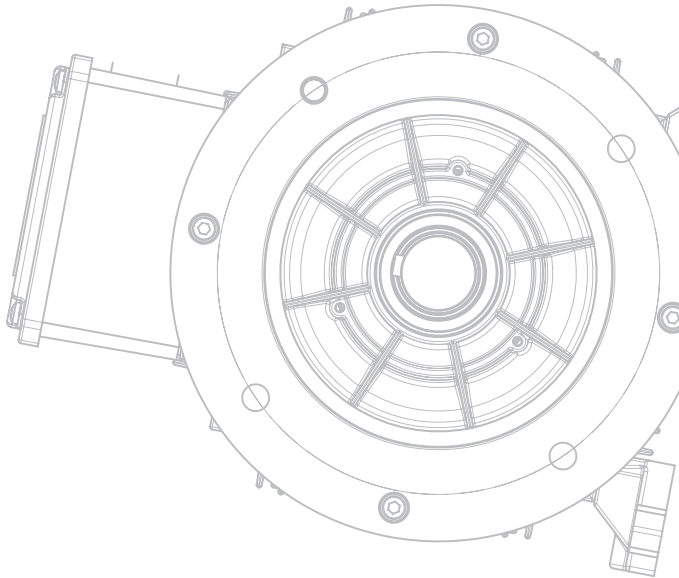
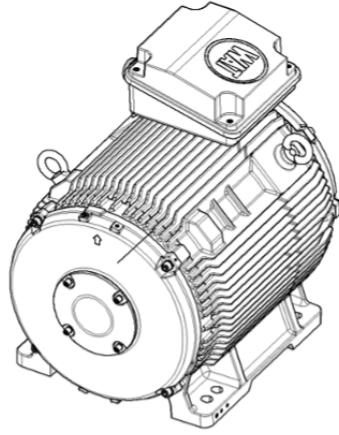
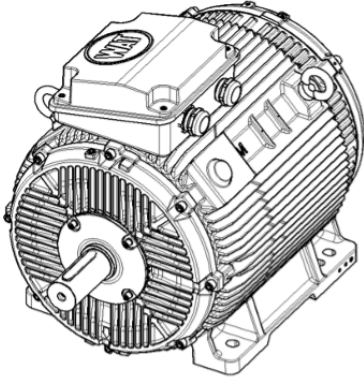

# B5 - B30 MOUNTING

**80 - 90 - 100 FRAMES**

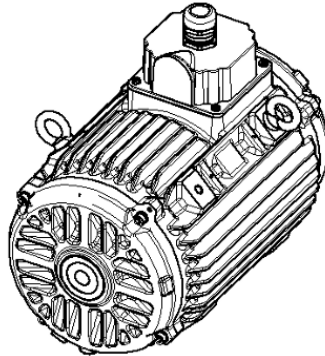
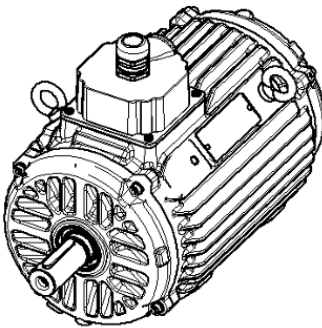
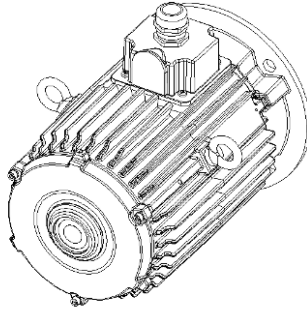
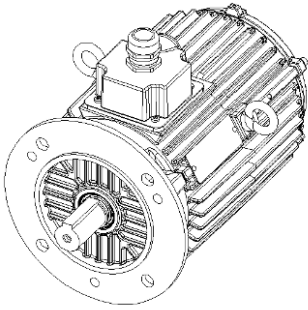

**112 - 132 - 160 - 180 - 200 FRAMES**

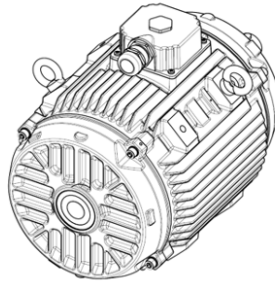
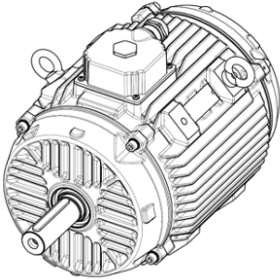
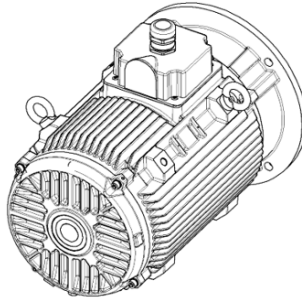
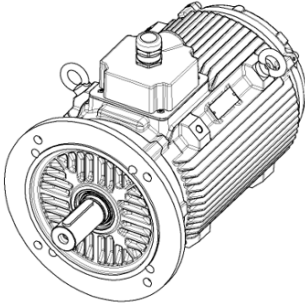

**225-250 FRAMES**

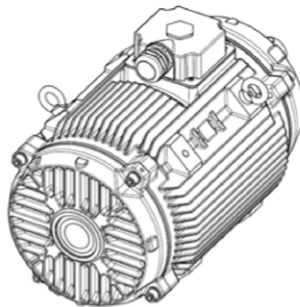
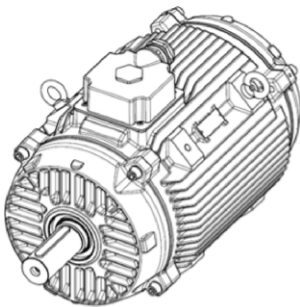

The cable and lug cross-sections used in F300 and F400 Smoke Exhaust Motors are as follows.

<b>80 FRAME</b>	6 BRUSHES X 0,75 mm <sup>2</sup>	M4 / 0,75 mm <sup>2</sup>
<b>90 FRAME</b>	6 BRUSHES X 1 mm <sup>2</sup>	M5 / 1 mm <sup>2</sup>
<b>100 FRAME</b>	6 BRUSHES X 1 mm <sup>2</sup>	M5 / 1 mm <sup>2</sup>
<b>112 FRAME</b>	6 BRUSHES X 1.5 mm <sup>2</sup>	M5 / 1,5 mm <sup>2</sup>
<b>132 FRAME</b>	6 BRUSHES X 2.5 mm <sup>2</sup>	CABLE LUG (2.5-6 mm <sup>2</sup> )
<b>160 FRAME</b>	6 BRUSHES X 4 mm <sup>2</sup>	CABLE LUG GK 8-6
<b>180 FRAME - 22 kW - 2 POLES ONLY</b>	6 BRUSHES X 2 X 2,5 mm <sup>2</sup>	M10 CABLE LUG10-6
<b>180 FRAME</b>	6 BRUSHES X 6 mm <sup>2</sup>	CABLE LUG GK 8-6
<b>200 FRAME</b>	6 BRUSHES X 2 X 4 mm <sup>2</sup>	M10 CABLE LUG10-6
<b>225 FRAME</b>	6 BRUSHES X 2 X 6 mm <sup>2</sup>	M10 CABLE LUG10-6
<b>250 FRAME</b>	6 BRUSHES X 16 mm <sup>2</sup>	M10 CABLE LUG10-6
<b>280 FRAME</b>	6 BRUSHES X 25 mm <sup>2</sup>	CABLE LUG35
<b>315 FRAME</b>	6 BRUSHES X 2 X 25 mm <sup>2</sup>	M12 CABLE LUG50



# MARINE MOTORS

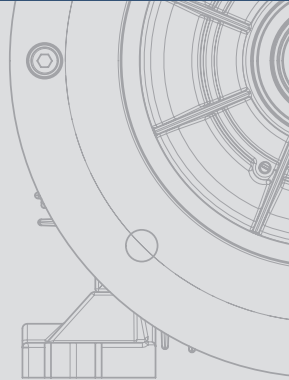

Motors used in maritime applications such as ships, yachts, and offshore drilling units, which are resistant to salty and humid atmospheric conditions and approved by a Classification Institution, are defined as Marine Motors.

Marine motors, unlike conventional electric motors, are motors designed and certified for the conditions of the maritime industry (ships, yachts, offshore applications, etc.). Since the areas where they are used differ from land-based areas in terms of both atmospheric conditions and electrical infrastructure, designs and components that meet customer requirements are needed.

Marine motors are used in ships and yachts in sections such as fans, pumps, cranes, compressors, winch motors, and propulsion motors; and in offshore oil and gas platforms. They usually operate in salty and humid atmospheric conditions. Therefore, the motor shall adapt to the conditions and have a high corrosion resistance.

<b>Classification Institution:</b>	Bureau Veritas (BV)
<b>Body Material:</b>	Aluminum- (80-225 Fr)
	Pik-GG20(80-280 Fr)
<b>Power Range:</b>	0,75 kW-90 kW
<b>Efficiency Class:</b>	IE2-IE3 (IEC 60034-30) [2]
<b>Number of Poles:</b>	2, 4,
<b>Corrosion Class:</b>	C3 (Medium) or C5 according to ISO 12944-5
<b>IP Protection Class:</b>	IP55
<b>Color Range:</b>	RAL XXXX
<b>Shaft Material:</b>	SHAFT STEEL SAE1040 (C35), SAE 1.4021 X20Cr13 Stainless Steel upon request
<b>Frequency:</b>	50 Hz- 60 Hz
<b>Voltage:</b>	220 - 380-400 - 690 V (IEC 60038)
<b>Operating Ambient Temperature:</b>	- 20 / + 60

<b>Insulation Class:</b>	Class F (155 °C) or Class H (180 °C) according to IEC 60034-1
<b>Temperature Rise:</b>	Class B (80 °C) according to IEC 60034-1
<b>Protection Class:</b>	IP 55 according to IEC 60034-5
<b>Ambient Temperature:</b>	45°C according to IEC 60034-1
<b>Cooling Method:</b>	IC411 (TEFC) or IC410 according to IEC 60034-6
<b>Drainage Holes:</b>	Anti-condensation drainage holes in the covers
<b>Thermal Protection:</b>	PTC, and PTO, PT100 as an option
<b>Seal:</b>	Dust Seal (Selected from 6416006xx)
<b>Noise Limits:</b>	IEC 60034-9 and current catalogue limits
<b>Vibration Limits:</b>	1/2 Key according to IEC 60034-14, vibration class A
<b>Identification plate:</b>	Stainless steel.
<b>Motor Sizes:</b>	Motor Sizes: To be designed in accordance with EN 50347.
<b>Bearing Life:</b>	Min. 20.000 h
<b>Shaft End Forces:</b>	The current catalogue for motors with aluminium bodies shall be used as a basis. The cast iron motor catalogue for motors with cast iron bodies shall be used as a basis.

### C3 Medium and C5-M High Corrosion Resistances

Resistance to atmospheric conditions is classified into 6 corrosive categories according to ISO 12944-5. These categories are given in the table below. The current range of industrial products is painted according to C2 (low). The marine motor product range is painted as standard to C3 (Medium) and optionally to C5-M (Very High) (Marine).

#### Corrosive atmosphere categories according to ISO 12944-5

<b>C1</b>	very low	<b>C4</b>	high
<b>C2</b>	low	<b>C5-I</b>	very high (industrial)
<b>C3</b>	medium	<b>C5-M</b>	very high (marine)

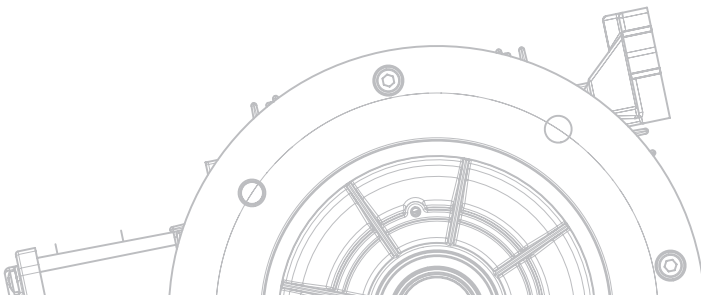

### For corrosion resistance C3 (Medium)

Polyurethane Primer → Paint → Furnace → C3 (Medium)

### For corrosion resistance C5M (High)

Epoxy → Furnace → Polyurethane Primer → Paint → Furnace → C5-M (Very High)

For demands for marine motors below 100 kW, the certification documents are prepared based on the type approval certificate via the relevant order number. (This is a certificate prepared for design and is issued for the same product group.)

Approval for design documents → DNV test and approval → Company inspection → Issue of certificates based on type tests after production

For motors above 100kW, the certificate for the product is issued after the production process and tests for the manufactured motor are carried out in the company of the type approval organisation.

Submission of documents for approval → Planning for DNV audits → Verification in the field → Performance of tests with the DNV team

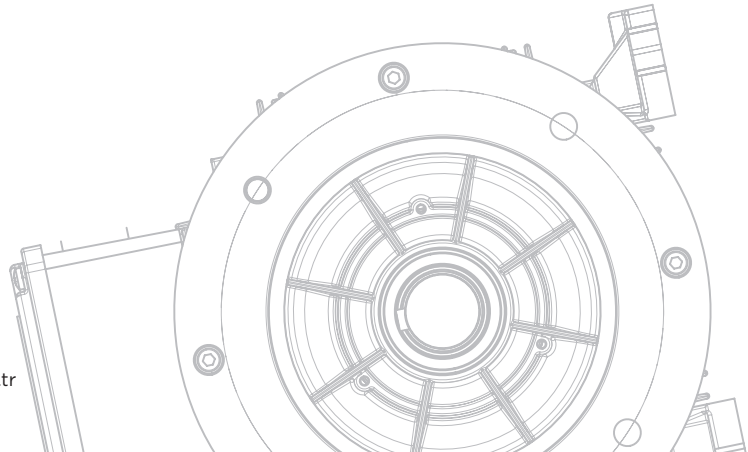

 <b>WAT Motor Sanayi ve Ticaret A.Ş.</b> Karaöğüz Mah. 8 Sok. No: 4/A 2 Kapaklı / Tekirdağ - TÜRKİYE	<b>3 PHASE CAGE INDUCTION MARINE MOTOR (TEFC)</b>	
	Model : M3HFA132M4D-KI Output Power (kW) : 7,5 Supply Voltage [V] : 400 Frequency [Hz] : 50 Current [A] : 14,6 Speed min <sup>-1</sup> : 1464 cos φ : 0,83	Standard : IEC 60034-30-1:2014 Efficiency % IE3 : 90,4 IEC 60034-2-1:2014 Ins. Class : F Protection CI : IP56 Duty Type : S1 Serial No : 09230001 * Comply with LVD Directives

Ambient Temp.	Resistance of Stator Winding (U1 - U2) at 25C		Temp. Rise (Steady State)	
	24 °C	25 °C	Thermal Equilibrium	Frame Stator Winding
			1,317 ohm	32,05 °C 52,02 °C

<b>NO LOAD TEST</b>				<b>High Voltage Test (60 s)</b>	
Voltage [V]	Current [A]	Input Power [kW]	Power Factor cos φ	Stator 2000 V	
440	10,9	0,53	0,06		
400	7,81	0,37	0,07		
380	6,76	0,3	0,07	Insulation Resistance	
360	6,0	0,28	0,07	Stator > 300 Mega Ohm	

<b>LOCKED ROTOR TEST (D.O.L.)</b>				<b>BREAKDOWN</b>			
Voltage [V]	Current [A]	Input Power [kW]	Power Factor cos φ	Torque		Current	
				(Nm)	Mq/Mn	Iq/In	Nm
400	128,99	-	-	126,67	2,6	8,61	187,62 3,85

<b>LOAD TEST</b>								
Voltage [V]	Current [A]	Input Power [kW]	Power Factor cos φ	Efficiency %	Speed min	Torque Nm	Output Power	
							kW	Load
400	16,89	9,69	0,835	89,91	1464,3	56,65	8,62	115%
400	14,6	8,32	0,826	IE3-90,4	1464,2	48,79	7,5	100%
400	12,23	6,27	0,74	90,68	1477,7	36,68	5,62	75%
400	9,9	4,2	0,62	89,49	1485,7	24,24	3,75	50%

Test No : 22296	<b>TYPE TEST CERTIFICATE</b>	Tested : G.GÖKTÜRK
Date : 29.11.2021	Tests were done in WAT Motor Test Laboratory WAT Motor Sanayi ve Ticaret A.Ş. Karaöğüz Mah. 8 Sok. No: 4/A 2 Kapaklı / Tekirdağ - TÜRKİYE	Approved:

 <b>WAT Motor Sanayi ve Ticaret A.Ş.</b>	<b>WAT Marine Motor W Certificate</b>			
	Customer	XXXXXXXX	Certificate number	54469/A1
			Issue date	13.11.2023
<b>Label information</b>				
Motor power	kW	0,75	Order number	XXXXXX
Nominal voltage	V	400	Model	M3H0M4D-KI
Nominal Current	A	1,75	Serial number	XXXXXX
Rated Speed	min <sup>-1</sup>	1450	Sales representative	
Frequency	Hz	50	IP class	IP56
Nominal moment	Nm	5,04	Efficiency class	IE3
Power factor	cos φ	0,77	Description	
Phase	-	3		
Efficiency	IE Code	82,5		
NOTE: Complies with Bureau Veritas' Rules for the Classification of Steel Ships' rule book, coded "NR467 - July 2019/Part C", AND the EN 60034-1:2010+ AC:2010 standard.				



The operating instructions to be followed for our marine motors certified by BV are the same as the operating instructions for general purpose motors. During the certification and production process of our marine motors, traceability is established for each product, and the relevant measurements and tests are recorded.

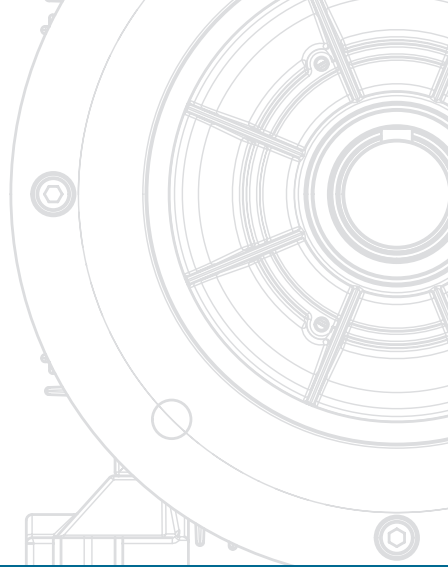

**WAT MOTOR SANAYİ VE TİCARET A.Ş.**  
KARAAĞAÇ MAHALLESİ 8. SOKAK NO:4 A/2  
KAPAKLI 59510 TEKİRDAĞ, TURKEY



[wat.com.tr](http://wat.com.tr)