



WAT Motor  
Sanayi ve Ticaret A.Ş.



### Three Phase Squirrel Cage Induction Motor

Motor Type: Q3EPA71M2B

#### Electrical Data

RATED VALUES						STARTING VALUES				BREAKDOWN	EFFICIENCY			EFFICIENCY CLASS			
VOLTAGE	POWER		SPEED	CURRENT	TORQUE	Cos φ	CURRENT			TORQUE	TORQUE Mk/ Mn Nm	EFFICIENCY			IEC 60034-30-1		
V	kW	Hz	rpm	A	Nm	4/4	$I_A / I_N$	Y	D	$M_A / M_N$		Y	D	4/4	3/4	2/4	IE
230/400	0,55	50	2808	2,26/1,31	1,9	0,80	6,2			3,8			3,8	77,8	74,1	69,5	IE3
265/460	0,55	60	3433	2,04/1,18	1,5	0,78	5,92			4,22			5,03	76,8	73,1	68,6	IE3

#### Mechanical Data

Bearing DE	6202-ZZ	Color	Optional
Bearing NDE	6202-ZZ	Motor protection	Optional
Lubricants	Shell Gadus S2 V100Q2	Method of cooling	IC 411
Condensation drain hole	No	Terminal box position	Top
External earthing terminal	Yes	Material of terminal box	Aluminium
Vibration class	A	Terminal plate thread	M4
Insulation class	F	Cable gland	1xM20
Duty type	S1	Clamping range	10-14 mm
Direction of rotation	Clockwise	Mounting type	IM 2001 (B35)
Housing material	Aluminium		
Type of balancing	Half Key		

#### Environmental Data

#### Others

Ambient temperature	-20 / + 40 °C	Type of protection	IP56
Altitude above sea level	1000 m	Sound pressure level 50/60Hz	dBA 62
		Moment of inertia (kgm <sup>2</sup> )	0,00057
		Standard	IEC 60034-1
		Weight (kg)	7,0

#### Dimensions

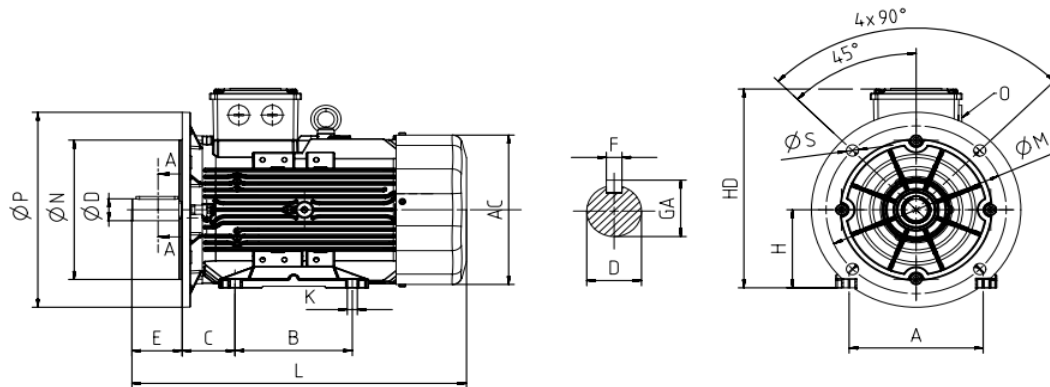

Main Dimensions		Foot Mounted Motors						Shaft				Flange Mounted Motors			
AC	L	B	A	H	HD	K	C	D	E	GA	F	P	N	M	S
138	253	90	112	71	178	7	45	14	30	16	5	160	110	130	10

B34b