



WAT Motor
Sanayi ve Ticaret A.Ş.



Smoke Extraction Motor F300 2 Hour EN 12101-3

Motor Type: S3H160L4A40-KG

Electrical Data

RATED VALUES						STARTING VALUES			BREAKDOWN		EFFICIENCY			EFFICIENCY CLASS	
VOLTAGE V	POWER kW Hz		SPEED rpm	CURRENT A	TORQUE Nm	cos φ	CURRENT I _A / I _N Y D		TORQUE M _A / M _N Y D		TORQUE Mk / Mn Nm		IEC 60034-30-1		
	4/4	3/4	2/4	4/4	3/4	2/4	4/4	3/4	2/4	4/4	3/4	2/4	IE		
400/690	11	50	1475	22,0/12,7	71,2	0,79		7,30		2,70	3,10	IE3-91,4	91,6	90,7	IE3
460/795	11	60	1777	19,3/11,2	59,1	0,81		7,20		2,50	2,90	IE3-92,4	92	89,8	IE3

Mechanical Data

Bearing DE	6309 ZZ C4 DUPONT260C ORS	Color	Optional
Bearing NDE	6209 ZZ C4 DUPONT260C ORS	Motor protection	Optional
Lubricants	Dupont GPL 226 Krytox (260 C°)	Method of cooling	IC 418
Condensation drain hole	No	Terminal box position	Top
External earthing terminal	Yes	Material of terminal box	Aluminium
Vibration class	A	Cable gland	M32x1.5
Insulation class	H	Clamping range	18-25
Duty type	S1	Mounting type	IM 1001 (B3)
Direction of rotation	Clockwise		
Housing material	Aluminium		
Type of balancing	Half Key		

Environmental Data

Others

Ambient temperature	-20 / + 40 °C	Type of protection	IP56
Altitude above sea level	1000 m	Sound pressure level 50/60Hz	dBA 63
		Moment of inertia (kgm ²)	0,05940
		Standard	IEC 60034-1
		Weight (kg)	90,0
		Resistance to fire	300 C° 2 Hour F300 EN 12101-3

Dimensions

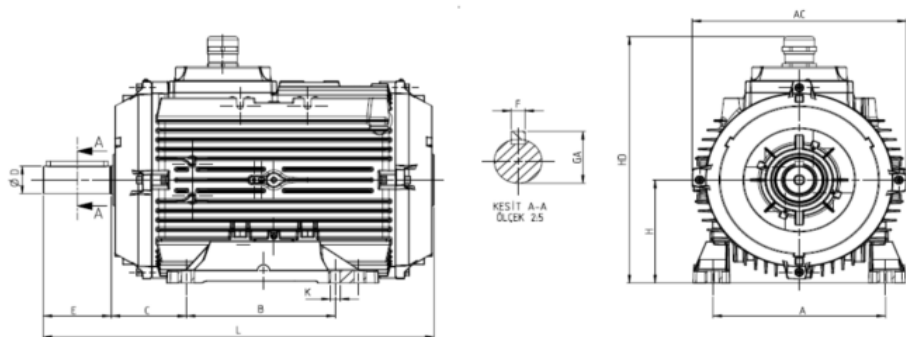

Main Dimensions		Foot Mounted Motors						Shaft				Flange Mounted Motors			
AC	L	B	A	H	HD	K	C	D	E	GA	F	P	N	M	S
314	539	210	254	160	374	14,5	108	42	110	45	12				