

NOT : Mil salgısı DIN EN 50347'ye uygun olmalıdır.  
DIN EN 50347 için 6411107xx nolu resme bakınız.  
Max salgı değeri için "normal" sütununa bakınız

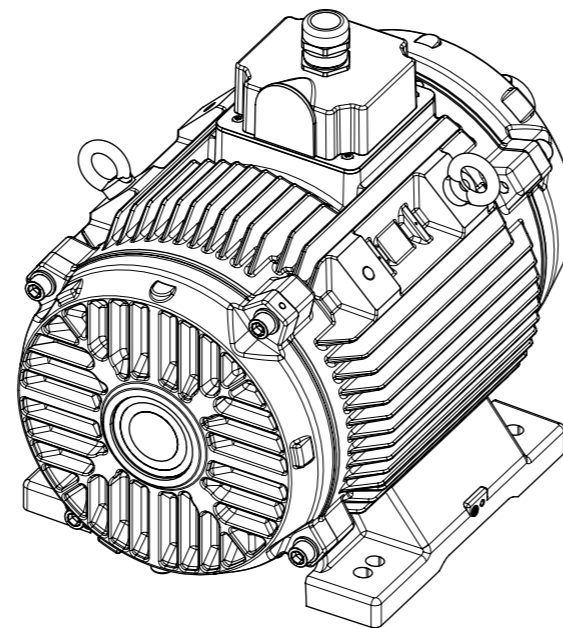

(K07)

Dimension (incl. runout and flatness) of drive end side feet are according to DIN EN 50347

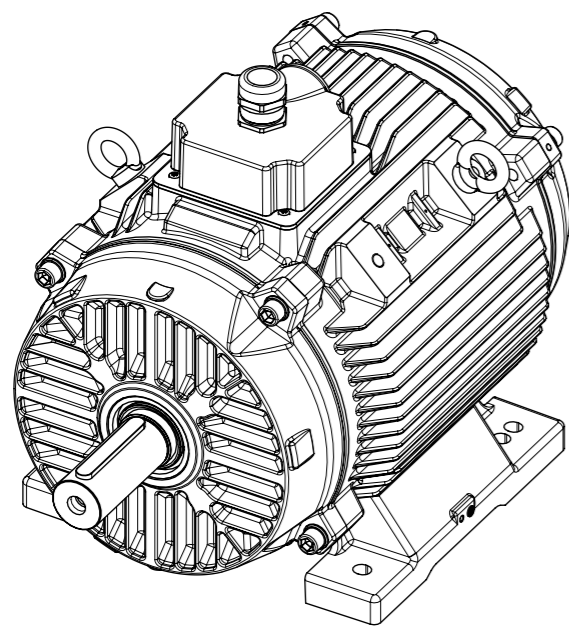

PARÇAKOMPONENT VE BUNLARI OLUŞTURAN HAMMADDE, BOYA, KAPLAMA VS KL-00093 ARÇELİK KİMYASAL UYGUNLUK ŞARTNAMESİ'NE UYGUN OLMALIDIR.	RAW MATERIAL, INCLUDING ALL THE ADDITIVES, PAINT, COATINGS ETC OF THE PART/COMPONENT SHALL CONFORM TO ARÇELİK PROCEDURE, KL-00093 CHEMICAL COMPLIANCE SPECIFICATIONS.
TASARIM, MALZEME VE ÜRETİM PROSESİNDEKİ DEĞİŞİKLİKLERDEN ÖNCE ONAY GEREKLİDİR.	APPROVAL IS REQUIRED BEFORE DESIGN OR MATERIAL OR PROCESS CHANGES.

1	Yeni yayınlandı	AA	CR*	09.03.2022	E.S.
REV NO	DEĞİŞİKLİK	DEĞ KOD	YAYIN NO	REV.TARİHİ	İMZA

MALZEME	TARİH	09.03.2022	İMZA	 <b>WAT MOTOR</b> SANAYİ VE TİCARET A.Ş.
	HAZIRLAYAN	E.SAYAR		
	KONTROL	E.SAYAR		
	KONTROL	M.A.CALDUK		
	ONAY	B.T.ERTUGRUL		

ÖLÇEK	DIS GORUNUS S3HG225-4 B3	REFERANS RESİM NO
1:5	OUTLOOK VIEW S3HG225-4 B3	SAYFA / TAMAMI 1/1 A3

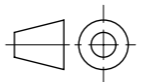
	GENEL TOLERANSLAR(VERİLENLER DIŞINDA) ISO 2768-m			RESİM NO
	UZUNLUK	>= 6mm ±0,1	30-120mm ±0,3	400-1000mm ±0,8
6-30mm ±0,2	120-400mm ±0,5	1000-2000mm ±1,2		
AÇI	>= 10mm ±1°	50-120mm ±20'	>= 400mm ±5'	
	10-50mm ±30'	120-400mm ±10'		

○ Oblong işareti, istatistiksel proses kontrolü yapılacak ölçüleri tarifler  
Oblong sign is used for definiq statistical process control dimensions

Ⓚ K sembolü kalite kontrol ölçüleridir.  
K symbol is used for Quality Control dimensions.