



WAT Motor
Sanayi ve Ticaret A.Ş.

Smoke Extraction Motor F400 2 Hour EN 12101-3



Motor Type: S3HG250M2C40-KG

Electrical Data

RATED VALUES							STARTING VALUES				BREAKDOWN	EFFICIENCY			EFFICIENCY CLASS
VOLTAGE V	POWER kW Hz		SPEED rpm	CURRENT A	TORQUE Nm	Cos Φ 4/4	CURRENT I_A / I_N Δ Y		TORQUE M_A / M_N Δ Y		TORQUE Mk/ Mn Nm	%			IEC 60034-30-1 IE
	400/690	55	50	2985	93.2/53.8	176.0	0.91	10.3	-	4.1	-	3.3	IE3-94.3	93.8	92.2
460/795	55	60	3588	81.5/47.1	146.4	0.91	9.8	-	4.6	-	4.4	IE3-93.6	93.1	91.5	IE3

Mechanical Data

Bearing DE	6314 ACIK C4 YOK ORS	Color	Optional
Bearing NDE	6314 ACIK C4 YOK ORS	Motor protection	Optional
Lubricants	Dupont GPL 226 Krytox (260 C°)	Method of cooling	IC 418
Condensation drain hole	No	Terminal box position	Top
External earthing terminal	Yes	Material of terminal box	Cast Iron
Vibration class	A	Cable gland	M50x1.5
Insulation class	H	Clamping range	34-44 mm
Duty type	S1	Mounting type	IM 1001 (B3)
Direction of rotation	CW		
Housing material	Cast Iron		
Type of balancing	Half Key		

Environmental Data

Ambient temperature	-20 / + 40 °C
Altitude above sea level	1000 m

Others

Type of protection	IP 56
Sound pressure level	dBA 78/81
Moment of inertia (kg.m ²)	0.93
Standard	IEC 60034-1
Resistance to fire	400 C° 2 Hour F400 EN 12101-3

Dimensions

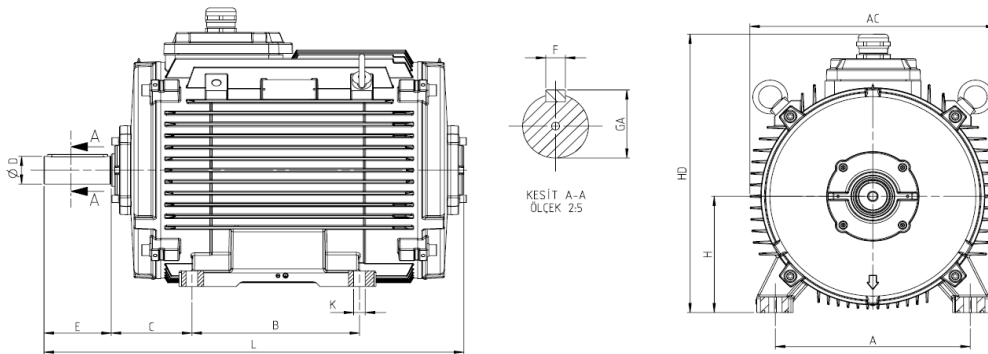

Main Dimensions		Foot Mounted Motors						Shaft					Flange Mounted Motors			
AC	L	B	A	H	HD	K	C	D	E	GA	F	P	N	M	R	
512.2	874	311	406	250	546.1	24	168	60	140	64	18	-	-	-	-	