



WAT Motor
Sanayi ve Ticaret A.Ş.



Smoke Extraction Motor F300 2 Hour EN 12101-3

Motor Type: S4HP280M4D40-KG

Electrical Data

RATED VALUES							STARTING VALUES			BREAKDOWN	EFFICIENCY			EFFICIENCY CLASS	
VOLTAGE V	POWER kW Hz		SPEED rpm	CURRENT A	TORQUE Nm	Cos ϕ	CURRENT I_A / I_N		TORQUE M_A / M_N		TORQUE Mk/ Mn Nm				IEC 60034-30-1
	4/4	Y	D	Y	D	Y	D	Y	D	4/4	3/4	2/4	IE		
400/690	90	50	1492	153,1/88,5	576,0	0,88		7,9		2,4	3,4	IE4-96,1	96,0	95,2	IE4
460/795	90	60	1794	146,4/84,6	479,1	0,81		7,5		2,7	4,5	IE4-96,2	96,1	95,3	IE4

Mechanical Data

Bearing DE	6317 ACIK C4 YOK ORS	Color	Optional
Bearing NDE	6317 ACIK C4 YOK ORS	Motor protection	Optional
Lubricants	Dupont GPL 226 Krytox (260 C°)	Method of cooling	IC 418
Condensation drain hole	No	Terminal box position	Top
External earthing terminal	Yes	Material of terminal box	Cast Iron
Vibration class	A	Cable gland	M50x1.5
Insulation class	H	Clamping range	34-44
Duty type	S1	Mounting type	IM 1001 (B3)
Direction of rotation	Clockwise		
Housing material	Cast Iron		
Type of balancing	Half Key		

Environmental Data

Others

Ambient temperature	-20 / + 40 °C	Type of protection	IP56
Altitude above sea level	1000 m	Sound pressure level 50/60Hz	dBA 70
		Moment of inertia (kgm ²)	1,8414
		Standard	IEC 60034-1
		Weight (kg)	694,0
		Resistance to fire	300 C° 2 Hour F300 EN 12101-3

Dimensions

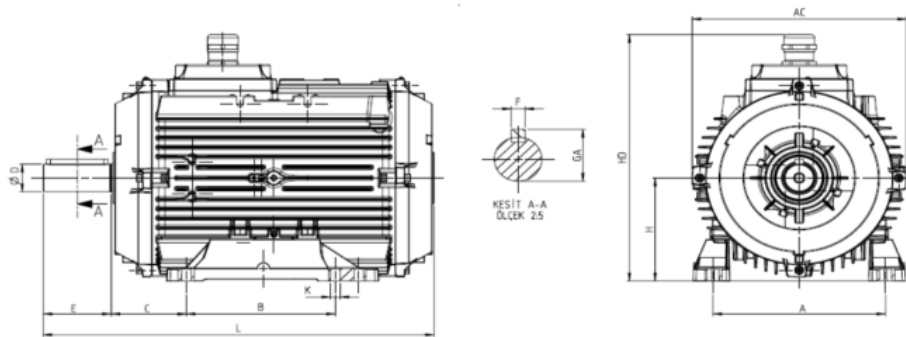

Main Dimensions		Foot Mounted Motors						Shaft				Flange Mounted Motors			
AC	L	B	A	H	HD	K	C	D	E	GA	F	P	N	M	S
574	913	368	457	280	658	24	190	75	140	79,5	20				